

- 
- Heterophase Polymerization
 - Biomimetic Mineralization and Crystal Growth Control
 - Chimera Polymers and Novel Polymerization Techniques
 - Modern Techniques of Colloid Analysis
 - Materials for Energy Applications
 - Hydrothermal Carbon Nanostructures and Coatings
 - De Novo Nanoparticles
 - International Joint Laboratory

COLLOID CHEMISTRY

Research in the Department of Colloid Chemistry

Scientific Profile

The size of the Department of Colloid Chemistry is currently about 60 people, with many independent researchers covering a wide range of research topics. The effective constituting element of the scientific activities is the "project", structure headed by a senior scientist involving a mixture of technicians, graduate students and post-docs (3-8 people). Projects are related to scientists, but have a temporal character of usually about 5 years. After this time, permanent scientists have to redefine their profile to justify the allocation of resources. In the case of non-permanent scientists, the projects usually leave the department with the promotion of the scientist, i.e. the group leaders can continue their specific research in their new academic environment (usually as professors) without competition of the former group.

In the time of this report and after a "drain" of 4 group leaders in the period ahead, reconstruction of the department went on and was most serious. Dr. Arne Thomas, head of the ENERCHEM project is in the process of leaving the institute towards a full professorship (TU Berlin), and the Emily Noether group of Dr. Hans Börner is also developing towards a professorship. The new group of Dr. Maria Magdalena Titirici on "Hydrothermal Carbon" was complemented in October 2008 by two other new groups, Dr. Cristina Giordano ("De Novo Nanoparticles"), and Dr. Xinchun Wang ("Artificial Photosynthesis"), who however are mainly involved in build-up operations. This turnover is beyond typical and not easy, but reflects the dynamic character of the department.

The profile of the department has therefore been seriously reoriented, keeping only some of the old strongholds. The following topics are treated by the department:

- Heterophase Polymerization
- Biomimetic Mineralization and Crystal Growth Control
- Chimera Polymers and Novel Polymerization Techniques
- Modern Techniques of Colloid Analysis
- Materials for Energy applications
- Hydrothermal Carbon Nanostructures and Coating
- New inorganic nanoparticles
- Artificial photosynthesis

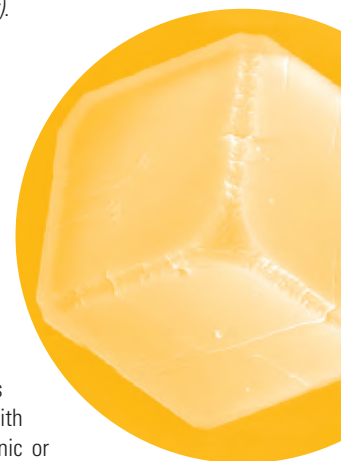

These projects within these project groups are briefly explained below:

Heterophase Polymerization

The notation "Heterophase Polymerization" summarizes the techniques of suspension-, emulsion-, mini-, and microemulsion-polymerization as well as precipitation polymerization. The solvent is usually water, but heterophase polymerization in inverse media is also examined. This class of techniques, although more than 90 years old, experiences a strong renaissance, since it allows the production of high polymer containing formulations in water as an environment-friendly solvent.

Central points of interest of the team working on heterophase polymerization are:

- We want to gain a better understanding of the nucleation period and particle formation for an optimal control of the particle size and polydispersity. For this purpose, new experimental online multidetection techniques are developed; the experimental investigations are supplemented by theoretical and numerical descriptions (*Dr. Klaus Tauer*).
- We want to simplify the synthesis of complex polymer morphologies on a molecular level (synthesis of block & graft copolymers by emulsion polymerization) and on a colloidal level (core-shell lattices, hollow spheres, one-step synthesis of reinforced materials) by a rational use of the particle interfaces in heterophase polymerization (*Dr. Klaus Tauer*).

Biomimetic Mineralization and Crystal Growth Control

Polymers can step in the precipitation of inorganic and organic molecules and control the growth of the nucleated particle. Here, we are mainly (but not exclusively) interested in so-called double-hydrophilic block copolymers where one block mediates water solubility, whereas the other interacts with the surface of inorganic or polar organic particles.

- The solution structures of diverse minerals prior to crystallization are analyzed by on-line multidetection techniques. It turns out that the classical picture of nucleation is by far too simple could be redefined by inclusion of a whole set of different amorphous species (*Dr. Helmut Cölfen*).

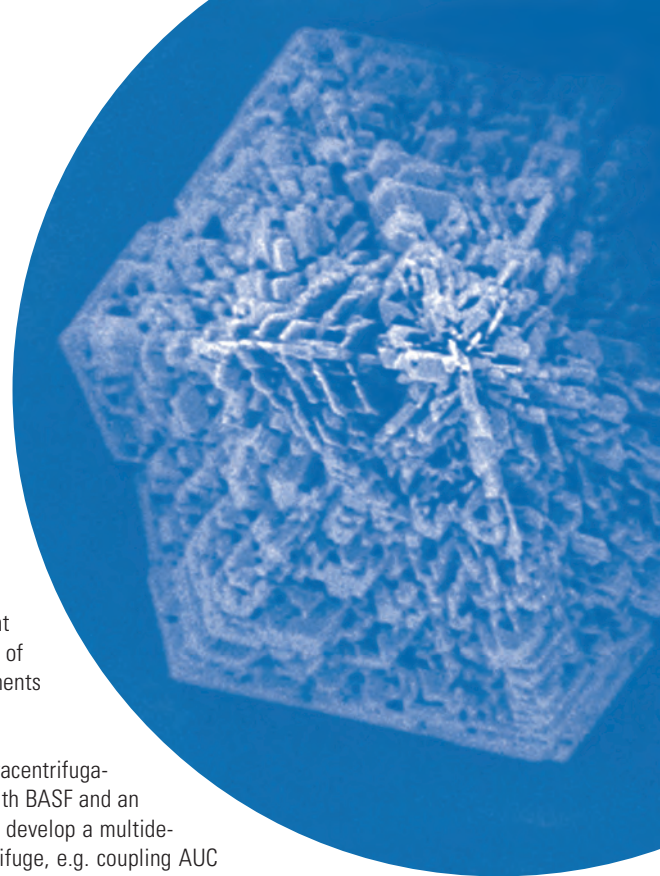

- The tectonic arrangement of nanoparticles can be controlled by the spontaneous action of polymers and allows, analogous to the model of bone or seashell, the construction of superior hybrid materials (*Dr. Helmut Cölfen, together with the Biomaterials Department*).
- These principles also enable the colloidal formulation of organic drugs and pigments (*Dr. Helmut Cölfen*). The origins of supramolecular chirality are analyzed.

Chimera Polymers and Novel Polymerization Techniques

Amphiphilic polymers consist of components which dissolve in different media, e.g. a hydrophilic and a hydrophobic part. Since we are able to adjust both components sensitively to the dispersion medium as well as to the dispersant, amphiphilic polymers allow the stabilization of unusual dispersion problems. Recently, we learned that very special effects, not only for biological interfaces, can be addressed when one block is a biopolymer, whereas the other mediates to the "technical world" (Chimera Polymers). Focal points of interest in this range are:

- The micelle formation and lyotropic liquid crystalline phase behavior of chimera polymers is examined in dependence of the molecular structure, the relative amount of the different components, as well as the secondary interactions between the structure forming bio-like blocks (*Dr. Helmut Schlaad*).
- The introduction of secondary interactions such as H-bridges, dipole interactions or metal-ligand binding results in superstructures with more complex order and broken symmetry (*Dr. Helmut Schlaad*).
- The performance of molecular drugs can be highly enhanced or optimized by coupling to a colloidal system with synergistic action. Here, our specific knowledge on the synthesis and physical behavior of functional polymers and colloids is used in cooperation with pharmaceutical/medical partners to generate tailor made colloidal drug carriers and diagnostics (*Dr. Hans Börner/ Dr. Helmut Schlaad*).

Modern Techniques of Colloid Analysis

All the work described above is necessarily accompanied by a considerable amount of colloid analysis which includes fully commercial techniques, but also relies on the development of new techniques or methods of data handling. The developments in this area include:

- The development of new ultracentrifugation techniques. Together with BASF and an American partner group, we develop a multidetector kit for the ultracentrifuge, e.g. coupling AUC separation with Raman-, UV- or fluorescence detection which allows an in-situ chemical analysis within a separating complex colloidal mixture. By opening a bunch of new possible scientific applications, we intend to revitalize the AUC. (*Dr. Helmut Cölfen, Project "Open AUC" together with the BASF AG*).
- Special techniques of transmission and scanning electron microscopy on soft, structured matter (*Dr. Jürgen Hartmann*).

Materials for Energy Applications

The Max Planck Society has established a new instrument to improve the impact and visibility of basic science for society, so-called project clusters or project houses. The first of these project houses to come into existence was ENERCHEM, devoted to the materials chemistry to handle energy problems. This project house was initiated by the Inorganic Chemistry Department of the Fritz Haber Institute and the Colloid Chemistry Department and is coordinated by Markus Antonietti.

Hydrogen storage, better fuel cells, new energy cycles, new catalysts for more efficient processes, methane activation, better batteries, ultracapacitors, remote energy storage, lightweight solar cells, all these topics are intimately connected with the control and design of materials nanostructure. Activities based in Golm include:

- New C/N-polymers and carbon materials to expand the property profile of carbon (*Markus Antonietti*)
- Porous tectonic polymers as membranes for fuel cells and battery separators and as novel gas storage materials (*Dr. Arne Thomas, on the leave*)

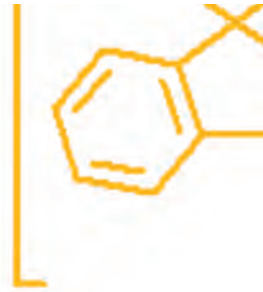
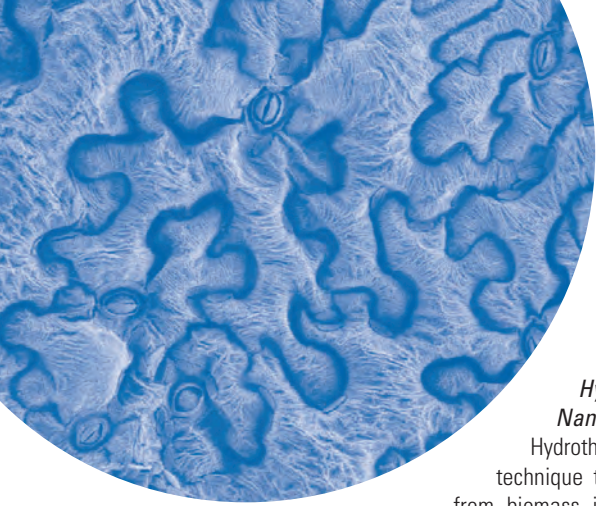

Hydrothermal Carbon Nanostructures and Coatings

Hydrothermal Carbonization is a 100 year old technique to generate carbonaceous materials from biomass in a colloidal heterophase reaction processes. We reactivated this process to address questions of the sustainable/chemical synthesis of carbon nanostructures and the climate change. First experiments indicate that not only the non-oil based raw material base ("sugar") is highly attractive; it is also that a multiplicity of appealing carbon nanostructures can be addresses with great ease and high potential:

- HTC of raw biomass to generate soil conditioner ("black soil") and its interaction with the microbial biosystem (Markus Antonietti, Maria Magdalena Titirici, together with the MPI of Biogeochemistry)
- Analysis of the elemental chemical steps of HTC and hybridization with technical monomers to generate new filler structures (Dr. Maria Magdalena Titirici)
- HTC reaction to coat nanoparticles and mesoporous scaffolds for catalysis, battery applications and modern chromatography (Dr. Maria Magdalena Titirici).

De Novo Nanoparticles

In spite of the fact that nanoscience is not exactly a new discipline, anymore, it is astonishing that the width of easily accessible nanostructures is still rather small, i.e. most experiments are done with a very restricted set of chemical systems, such as Au or CdS. Many materials which are relevant for novel energy cycles and to catalyze more efficient chemical reactions simply do not exist as appropriate nanostructures, or their synthesis is highly not sustainable and non practical. Because of that, "de novo" nanosystems and nanosyntheses have to be designed from scratch. Some cases of the project portfolio are:

- Metal carbide and nitride particles offer new pathways for metal/base catalysis, but also are record holders in mechanical hardness or magnetization (Dr. Cristina Giordano).
- This is also true for the corresponding metal borides and boronitrides, which are new land for chemistry, when rational nanostructures are to be made (Dr. David Portehault (CNRS SuperPostDoc program, together with Dr. Cristina Giordano).
- New cathode nanomaterials for the lithium batteries are another target where progress will directly impact society. Here, doping, superstructure formation and conductive coatings are additional issues to be addressed within synthetic protocols (Dr. Cristina Giordano).

Synthesis development in this group is always accompanied with the suitable physical characterization techniques. This includes, among others, high-resolution TEM microscopy, scattering techniques and magnetic characterization.

Artificial Photosynthesis

This international joint laboratory was established in July 2008 between the Max-Planck Institute of Colloids and Interfaces and Fuzhou University. It is intended to establish international research collaboration for artificial photosynthesis which are planned to be extended the next period.

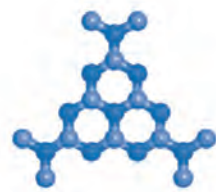

Natural photosynthesis, the process by which green plants are converting solar energy into chemical energy, has inspired the development of artificial versions of photosynthesis, i.e. (1) the splitting of water into hydrogen and oxygen, and (2) the conversion of carbon dioxide into organics via sunlight. An important challenge in artificial photosynthesis is the development of catalysts that should be sufficiently efficient, stable, inexpensive, and capable of harvesting the abundant visible light in solar spectrum. There are countless trials to establish stable systems for this purpose, mostly based on inorganic semiconductors with appropriately engineered band-gap and noble metals to promote the "extraction" of electrons. These materials include metal oxides, (oxy)sulfides, and (oxy)nitrides. This group investigates polymeric and organic-inorganic hybrid materials with controlled nanostructures as potential energy transducers for artificial photosynthesis. Potential applications include solar energy conversion, environmental purification, and organic synthesis. (Dr. Xinchen Wang)

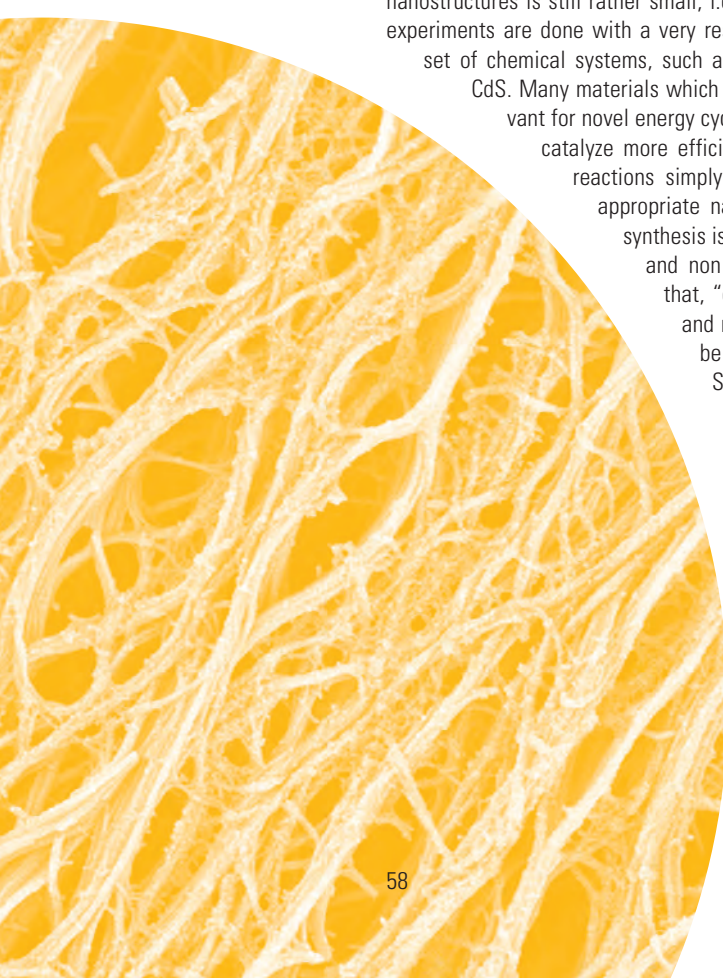

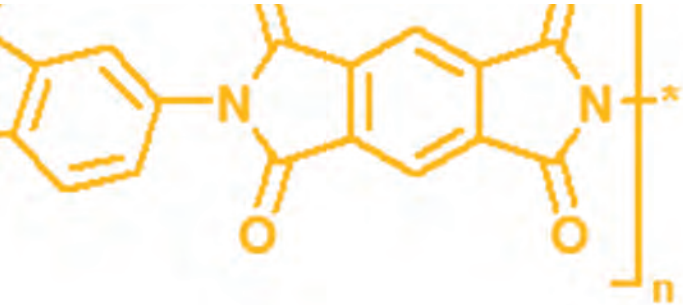

Visions and Future Perspectives for the Next Years

The group is continuing its way from a phase of being diversified in many junior projects to a period with more coordinated research and longer term goals.

As the TU Berlin has established a National Excellence Centre on Catalysis, it is a clear intention to further improve the cooperation with those colleagues, and a set of larger funding applications has been placed, thus hopefully allowing feed this interface with developed young persons. First scientific results from this cooperation are very promising.

The started projects on "Energy Materials" and "Processes for the Raw Material Change" turned out to be very timely and secured the department in the last four years clear visibility a leading European role in these activities. It is my personal intention to expand these activities.

Partly driven by the colloid department, but also by the other departments, we progress with the internationalization of our relations. Beside the well established Partner group at USCT/Hefei, we will enter a virtual "Artificial Photosynthesis Center" with the University of Fuzhou and Tokio University, become European Partner Group of the Iberian Center for Nanotechnology, and establish an Exchange Program with Kyushu University (together with Department of Interfaces).

Larger Equipment and Central Service Labs of the Department

Commercial standard techniques which are available in the department are:

- transmission and scanning electron microscopy,
- static and dynamic light scattering,
- diverse techniques of light microscopy,
- chromatographic lab including a number of modern chromatography techniques,
- reaction calorimetry with online multidetection,
- analytical and preparative ultracentrifugation,
- thermal analysis, DSC and porosimetry,
- MALDI-TOF-mass spectrometry,
- FT-ATIR for liquid analysis.

One of the labs, the electron microscopy lab, is a so-called "central service labs", i.e. it belongs and is operated by the department, but is also designated to perform scientific routine measurements for the whole institute. All other instrumental labs are not devoted to service operations, but are nevertheless heavily involved in inter-department projects.

Relations to Industry and Society

The department is involved in a large number of industrial projects. We promote fruitful and truly mutual relations with BASF AG, Firmenich, and Merck. These operations include scientific cooperation, knowledge exchange, consulting, the solution of minor scientific problems or measurements, and knowledge transfer to create the scientific base for products of the companies.

I am a board member of 15 scientific journals, and I consult the Royal Society of Chemistry/UK in questions of international exchange and benchmarking. In science policy, I regularly act as a referee in DFG, European and International science evaluations. I am a board member of the ERACHEM defining the future tasks of chemistry on the European level. I regularly go to schools and lecture about the problems of a developing society and how to respond on the base of scientific knowledge and education. In 2008, I received the ERC Senior Excellence grant for our colloid activities in sustainable chemistry. In 2009, I will receive the Polymer Medal of the UK Polymer group, which is a distinction for lifetime achievements.

Markus Antonietti,
Director of the Department
of Colloid Chemistry

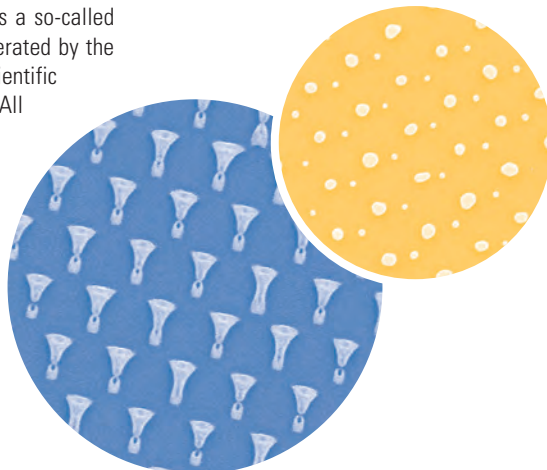
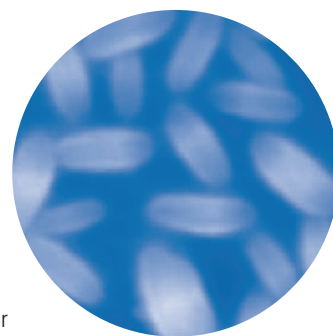

Polymer Dispersions/Heterophase Polymerizations



Spontaneous Emulsification

A closer look at the oil – water interface in the absence of any external shear reveals that droplets being created spontaneously on either side immediately after contacting two immiscible liquids (Fig. 1) [1, 2]. Freely moving oil drops in the water phase have been observed for polar oils but also for non-polar oils.

The water drops do not move but adhere to the glass walls of the observation cell and the shape of larger ones is non-spherical.

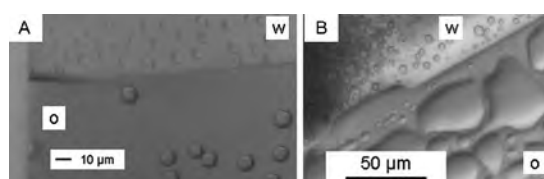

Fig. 1: Light microscopy images showing droplet formation on either side of the interface between A: chloroform – water and B: cyclohexane – water; o and w denotes the oil and water phase, respectively.

These experimental findings are crucial for developing the foundations of a consistent mechanism of heterophase polymerization (monomers are oils) and open new ways to modify latex particles.

Consistent Mechanism of Emulsion Polymerization

Spontaneous emulsification strongly influences both particle nucleation and swelling of particles [3, 4]. In the presence of monomer drops nucleation is for styrene EP heterogeneous in nature as illustrated by the TEM images of Fig. 2.

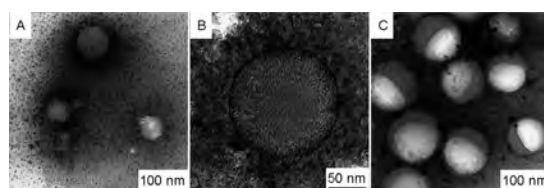

Fig. 2: TEM images illustrating the deposition of oligomeric particles onto styrene droplets during the early stage of unstirred emulsion polymerization; A: $t_{\text{equ}} = 5 \text{ min}$ after 40 minutes polymerization time, B: $t_{\text{equ}} = 120 \text{ min}$ after 30 minutes polymerization time, C: $t_{\text{equ}} = 180 \text{ min}$ after 30 minutes polymerization time

Accordingly, particle nucleation (that is the precipitation of water-born oligomers) is enhanced by the droplet interface and particle morphology depends on the monomer equilibration time (t_{equ}).

This scenario explains all the experimental observations from spontaneous emulsification and formation of vesicular or hollow particles at high initiator (persulfate) concentration. If however, the polymerization conditions are changed resulting in nucleated particles made of oligomers with higher molecular weights, which are soluble in the droplets, solid particles are formed (Fig. 3).

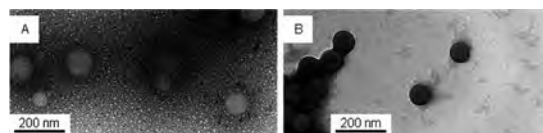

Fig. 3: TEM images of particles after polymerization time of 30 min for non-stirred surfactant-free emulsion polymerizations of styrene with 120 min monomer equilibration time; experimental conditions: all-glass reactor, 70 °C, 20 ml of styrene, 562.5 g of water, 1.25 g of KPS (A) and 0.094 g of KPS (B)

For more hydrophobic monomers such as *t*-butyl styrene the nucleation mechanism changes in dependence on initiator concentration. Droplet nucleation, that is, direct entry of radicals into monomer droplets, dominates at lower initiator concentrations.

Modification of Colloidal Particles

Colloidal polymer particles take up solvents without being dissolved. This swelling process is a complicated interplay between polymer and colloid chemistry and only poorly understood [3, 4]. Swelling takes place either via molecular diffusion of the swelling agent through the aqueous phase or via interaction with spontaneously formed droplets. In the latter case colloidal particles take up not only water insoluble materials but also substances with that they macroscopically only hardly interact. Exemplarily, polystyrene latex particles can be modified with poly(methyl methacrylate) [3, 4] or colloidal silica with paraffin wax [5].

Multiscale Modeling of Heterophase Polymerization

EP is a highly complex dynamic process in which chemical and physical events simultaneously occur at very different time and length scales. In free-radical polymerizations reaction rates range from about 1 to 10^9 s^{-1} and involve ions and molecules (size < 1 nm), macromolecules (1 – 10 nm), polymer particles (10 nm - 1 µm) and monomer droplets (up to > 1 µm).

The averaging of classical deterministic modeling clearly has limitation especially for considering details of heterogeneous systems.

Klaus Tauer 27.09.1951

1974: Diploma, Chemistry

(Friedrich-Schiller University Jena)

Thesis: Dye Sensitization of Photoconductivity of Poly(arylene vinylene) Polymers

1978: PhD, Polymer Chemistry

(Friedrich-Schiller University Jena)

Thesis: Investigations of spectral sensitization of photoconductivity of poly(arylene vinylene) polymers

1977-1991: Scientific Coworker

Institute of Polymer Chemistry of the Academy of Sciences of the GDR in Teltow-Seehof

Since 1992: Group Leader

(Max Planck Institute of Colloids and Interfaces, Potsdam)

Since 2004: "Privatdozent" Polymer Colloids, University of Potsdam

In the new multiscale modeling approach, different events are investigated at different time and length scales using suitable simulation methods such as Molecular Dynamics (MD) simulation, Brownian Dynamics (BD) simulation, and kinetic Monte Carlo (kMC) simulation. MD simulation is used to estimate the diffusion coefficients under the specific conditions. These diffusion coefficients are then used by the BD simulation method to describe the molecular motion at a much larger time and length scale. For instance, BD simulation is used to determine the rate of radical capture by polymer particles, [6] as well as the rate of radical desorption from the particles to the continuous phase [7]. Similarly, the BD method can be used to simulate monomer swelling dynamics [8].

BD simulations are extremely useful to achieve a deeper understanding of radical entry into latex particles as a key step in EP kinetics. Models relying on the Smoluchowski equation are insufficient as it is valid for a single particle at infinite dilution but in reality the polymer volume fraction Φ_p can be well above 50%. The numerical results (Fig. 4) show for a wide range of D (particle diameter) and N (particle number) that radical entry expressed by the Smoluchowski number depends linearly on Φ_p .

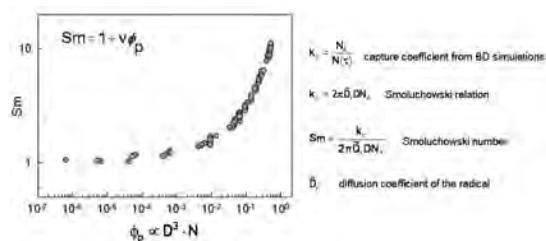

Fig. 4: Dependence of radical entry on Φ_p (BD simulations) [6]

Heterophase Polymerization as Synthetic Tool

Unique block copolymers are easily accessible by heterophase polymerization initiated with hydrophilic polymeric radicals [9]. This method relies on the fact that polymeric radicals can survive in isolated latex particles that are stabilized by hydrophilic blocks. The newly developed strategy of joint polymerization can be successfully applied to produce silica-containing block copolymer particles in a one-step procedure [5]. The hydrolytic condensation of the siloxanes takes place in the region of the block copolymer particles where the poly(N-isopropyl acrylamide) (PNIPAM) is located. This part is on the one hand hydrophobic enough to absorb the siloxanes and on the other hand it contains enough water to start hydrolytic condensation. The morphology of the SiO_2 that is obtained after calcination depends on the morphology and composition of the block copolymer particles (Fig. 5). Triblock copolymers with PNIPAM middle blocks lead regardless of the nature of the hydrophilic precursor polymer to spherical silica particles. If however, the core of the block copolymer particles consists of a hydrophobic polymer the morphology of the silica after calcination changes completely as a macroscopic solid with nanopores is obtained.

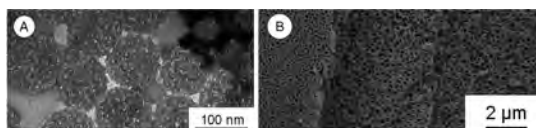

Fig. 5: TEM (A) and SEM (B) image of the silica obtained after calcination of various block copolymer particles; A: poly(styrene sulfonate)-PNIPAM-poly(vinyl trimethoxysilane) B: poly(ethylene glycol)-PNIPAM-poly(butyl acrylate)-poly(vinyl trimethoxysilane)

URT for Studying Phase Transitions [10, 11]

URT (ultrasound resonator technology) is considered to belong to the methods with an extremely high resolution in measurements of physical parameters of solutions and colloidal suspensions. The temperature behavior of various PNIPAM samples (block copolymers and microgels) has been studied.

Apparent activation free energies of the precipitation and re-dissolution of PNIPAM blocks have been determined for the first time. These are in the order of up to a few thousands kJ/mol, which can be explained by a high cooperativity of the precipitation process.

By combining TEM and AUC it was possible to show that PNIPAM at 40°C contains between 40 and 50 v-% of water. Besides free bulk water there is also bound water that strongly adheres to the N-isopropyl acrylamide units (about 25 v-%). Ultrasound resonator technology, which is non-sizing characterization method, revealed for PNIPAM microgel particles two more characteristic temperatures (at about 35 and between 40 and 50°C depending on the chemical nature) where distinctive changes in the ultrasound attenuation take place. Moreover, the experimental data suggests that the phase transition temperature is related to the surface charge density of the precipitated particles.

K. Tauer, H. Hernandez, O. Lazareva, H. Mert, P. Nazaran, N. Öz, N. Weber, U. Lubahn, S. Pirok, I. Shekova
klaus.tauer@mpikg.mpg.de

References:

- [1] Kozempel, S., Tauer, K., Rother, G.: Aqueous Heterophase Polymerization of Styrene – A Study by Means of Multi Angle Laser Light Scattering. *Polymer* **46**, 1169-1179 (2005)
- [2] Tauer, K., Kozempel, S., Rother, G.: The Interface Engine: Experimental Consequences. *J. Coll. Interf. Sci.* **312**, 432-438 (2007)
- [3] Tauer, K., Hernández, H., Kozempel, S., Lazareva, O., Nazaran, P.: Adaption of the Mechanism of Emulsion Polymerization to New Experimental Results. *Macromol. Symp.* **259**, 253-263 (2007)
- [4] Tauer, K., Hernández, H., Kozempel, S., Lazareva, O., Nazaran, P.: Towards a consistent mechanism of emulsion polymerization – new experimental details. *Coll. Polym. Sci.* **286**, 499-515 (2008)
- [5] Tauer, K., Weber, N., Nozari, S., Padtberg, K., Sigel, R., Stark, A., Völkel, A.: Heterophase Polymerization as Synthetic Tool in Polymer Chemistry for Making Nano-Composites. *Macromol. Symp.* in press
- [6] Hernández, H., Tauer, K.: Brownian Dynamics Simulation of the capture of primary radicals in dispersions of colloidal polymer particles. *Ind. Eng. Chem. Res.* **46**, 4480-4485 (2007).
- [7] Hernández, H., Tauer, K.: Radical desorption kinetics in emulsion polymerization 1. Theory and Simulation. *Ind. Eng. Chem. Res.* **47**, 9795-9811 (2008)
- [8] Hernández, H., Tauer, K.: Non-equilibrium molecular uptake by polymer particles in emulsion polymerization. In preparation
- [9] Tauer, K., Mukhamedjanjova, M., Holtze, Ch., Nazaran, P., Lee, J.: Unusual kinetics in aqueous heterophase polymerizations. *Macromol. Symp.* **248**, 227-238 (2007)
- [10] Tauer, K., Gau, D., Schulze, S., Hernández, H.: Transient-thermal and isothermal studies of thermo-sensitive polymer solution with ultrasound resonator technology. *Polymer* **49**, 5452-5457, (2008)
- [11] Tauer, K., Gau, D., Schulze, S., Völkel, A., Dimova, R.: Thermal Property Changes of Poly(N-isopropylacrylamide) microgel particles and block copolymers. *Coll Polym. Sci.* **287**, 299-312 (2009)

Bio-Inspired Mineralization



This project investigates biomineralization [1], practical aspects of biominerals like teeth [2, 3], bio-inspired mineralization [4-6] as well as the underlying principles and crystallization pathways in an attempt to understand and apply Nature's toolbox for the synthesis of sophisticated and complex hierarchical materials [7]. Such processes can be very advantageously controlled by polymer additives [8-10].

Amorphous precursor phases, which can be moulded into any desired shape prior to crystallization, are often found along these crystallization pathways. This strategy is applied by Nature but can also be mimicked for the generation of single crystals with complex form [6]. In addition, amorphous phases are involved in the polymorph control of minerals as could be demonstrated for CaCO_3 [11] – the Biomineral which we investigate most. Complex fluidic phases [12] or polymeric templates [13, 14] are also used to direct the crystallization event. It is for example possible to create nanopores with defined sizes in single crystals by templating with polymer micelles resulting in mesoporous single crystals [15].

Besides these regulation mechanisms for crystallization control, we are particularly interested in so-called non-classical crystallization pathways and mesocrystals [16, 17]. Nonclassical crystallization is a crystallization pathway which is based on nanoparticles involving their controlled superstructure formation in contrast to classical crystallization, which is based on the attachment of single atoms, molecules or ions.

The mutual orientation of the nanoparticles can even reach crystallographic order. Such crystals are called mesocrystals as abbreviation for mesoscopically structured crystals which show single crystal diffraction and light polarization properties but are composed of nanoparticles [16, 17]. To code the alignment of nanoparticles into mutual order, precise engineering of nanoparticle surfaces is necessary. However, little is so far understood about the formation mechanism of mesocrystals. We have therefore established a synthesis method for additive free high energy CaCO_3 crystal surfaces [18], which are usually not exposed, but regularly found in mesocrystals. These crystal faces as well as regular CaCO_3 crystal faces were investigated using single molecule force spectroscopy with the AFM [19].

This method allows to quantitatively detect adsorption/desorption forces of polymers on crystal surfaces and to learn about the nature of these interaction forces. Such results are an important prerequisite for the general understanding of polymer controlled crystallization. Indeed, significant differences were already detected for rather similar neutral CaCO_3 faces showing that our understanding of the precise nature of a crystal surface in a solvent is not yet mature [19]. We have therefore also looked at the effect of competitive solvent adsorption on crystal surfaces [20].

However, also only little is so far known about the formation mechanisms of mesocrystals and their fate along the crystallization pathway. If the nanoparticles in a mesocrystal are not at least weakly stabilized by a (polymer) additive, the nanoparticles can fuse their crystal surfaces, which are already in crystallographic alignment forming a single crystal. This fusion of crystal surfaces releases surface energy and could be monitored by small angle neutron scattering as demonstrated for DL-alanine by SANS showing that mesocrystals can be intermediates in the formation process of a single crystal [21].

Helmut Cölfen 24.07.1965

1991: Diploma, Physical Chemistry
(University of Duisburg)

Thesis: Analytical
Ultracentrifugation of Gels

1993: PhD, Physical Chemistry
(University of Duisburg)

Thesis: Analytical Ultracentrifugation of Gels

1993-1995: Postdoc (National Center for Macromolecular Hydrodynamics, University of Nottingham)

Since 1995: Group Leader
(Max Planck Institute of Colloids and Interfaces, Potsdam)

2001: Habilitation, Chemistry
(University of Potsdam)

Thesis: Biomimetic Mineralisation Using Hydrophilic Copolymers: Synthesis of Hybrid Colloids with Complex Form and Pathways towards their Analysis in Solution

Since 2004: Private Docent;
University of Potsdam

References:

- [1] Jäger, C.; Cölfen, H.: *Crystal Engineering Communications* **9**, 1237-1244 (2007).
- [2] Paris, S.; Meyer-Lueckel, H.; Cölfen, H.; Kielbassa, A. M.: *Dental Materials* **23**, 742-748 (2007).
- [3] Paris, S.; Meyer-Lueckel, H.; Cölfen, H.; Kielbassa Andrej, M.: *Dental Materials* **26**, 582-8 (2007).
- [4] Xu, A.-W.; Ma, Y.; Cölfen, H.: *Journal of Materials Chemistry* **17**, 415-449 (2007).
- [5] Cölfen, H.: *Nachrichten aus der Chemie* **56**, 23-27 (2008).
- [6] Cölfen, H.: *Angewandte Chemie, International Edition* **47**, 2351-2353 (2008).
- [7] Meldrum, F. C.; Cölfen H.: *Chemical Reviews* **108**, 4332-4432 (2008).

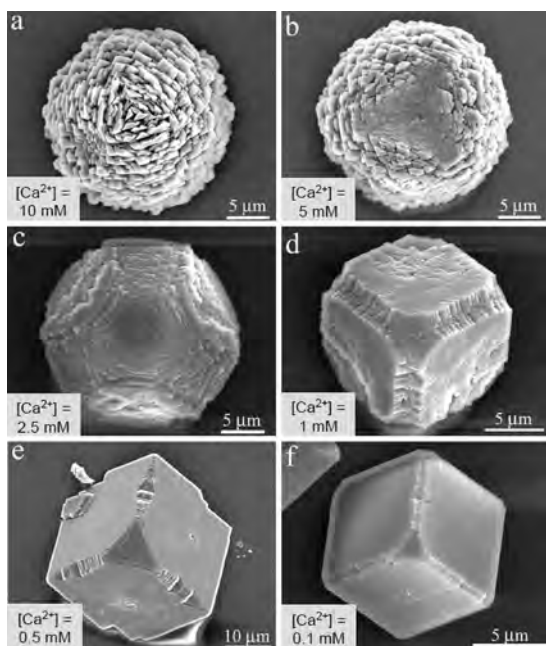

Fig. 1: Typical SEM images of calcite mesocrystals obtained different concentrations of Ca^{2+} and poly(ethyleneoxide)-block-poly(styrene-sulfonate) block copolymer with fixed $[\text{Ca}] : [\text{S}]$ ratio of 1.25 : 1. Image taken from Ref. [22]

On the other hand, mesocrystals are the intermediate between a single crystal and a polycrystalline aggregate of nanoparticles without any mutual order, with a continuous transition between these two structures. This was demonstrated for CaCO_3 , for which the structure could be tuned between a single crystal (**Fig. 1e**) and a polycrystalline aggregate (**Fig. 1a**) with increasing concentration of a structure directing block copolymer [22] (see **Fig. 1**).

Single particle X-ray diffraction at the Bessy microfocus beamline revealed a single crystal diffraction pattern for the particle in **Fig. 1c** although this structure is composed of multiple nanoparticles. Even for the polycrystalline aggregate in **Fig. 1a**, which appears unordered, some preferential orientation was still detectable.

Mesocrystals can also be formed with hierarchical structure. This was demonstrated for CaCO_3 formed in the presence of a commercial copolymer poly(styrene-alt-maleic acid) [23].

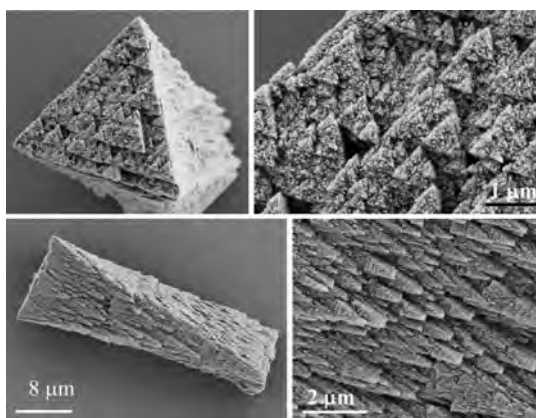

Fig. 2: SEM images of self-similar hierarchical calcite mesocrystals obtained at 1.25 mM $[\text{Ca}^{2+}]$ and 0.1 g/l poly(styrene-alt-maleic acid) Image taken from Ref. [23]

The triangular end faces (**Fig. 2** upper images) are polymer stabilized charged $\{001\}$ faces whereas the neutral $\{011\}$ faces are also self similar (**Fig. 2** lower images) but are not covered by the polymer and are responsible for the orientation of the crystallites into crystallographic register [23].

These results show that aggregation governs the length scales from a few tens of nm to a few tens of μm .

Investigations on the still smaller length scale down to the individual ions indicate, that even the primary nucleation event could be more an aggregation of stable CaCO_3 prenucleation clusters rather than an ion by ion growth as assumed in the classical theory of crystal growth [24]. The detected clusters form even in undersaturated CaCO_3 solutions where no nucleation occurs and are present already as soon as calcium and carbonate ions are mixed. These clusters were also found for the biominerals calcium oxalate and phosphate suggesting that clusters play a role in the precipitation of several minerals. Our results highlight the role of aggregation on different length scales in crystallization.

H. Cölfen, M. Barth, S.F. Chen, D. Gebauer, Y. Jiang, M.H. Huang, C. Lausser, M.G. Page, R.Q. Song, A.W. Xu, A. Verch, Coelfen@mpikg.mpg.de

[8] Cölfen, H.: In *Macromolecular Engineering, Precise Synthesis, Materials Properties, Applications: Applications*, Matyjaszewski, K.; Gnanou, Y.; Leibler, L., Eds. Wiley-VCH: Weinheim, 2007; Vol. 4, pp 2597-2643.

[9] Cölfen, H.: In *Biomaterialization II*, Naka, K., Ed. Springer: Berlin, Heidelberg, 2007; Vol. 271, pp 1-77.

[10] Neira-Carrillo, A.; Acevedo, D. F.; Miras, M. C.; Barbero, C. A.; Gebauer, D.; Cölfen, H.; Arias, J. L.: *Langmuir* 24, 12496-12507 (2008).

[11] Xu, A.-W.; Dong, W. F.; Antonietti, M.; Cölfen, H.: *Advanced Functional Materials* 18, 1307-1313 (2008).

[12] Cölfen, H.; Page, M. G.; Dubois, M.; Zemb, T.: *Physicochemical and Engineering Aspects* 303, 46-54 (2007).

[13] Martinez, Y.; Retuert, J.; Yazdani-Pedram, M.; Cölfen, H.: *Journal of Materials Chemistry* 17, 1094-1101 (2007).

[14] Ethirajan, A.; Ziener, U.; Chuvilin, A.; Kaiser, U.; Cölfen, H.; Landfester, K.: *Advanced Functional Materials* 18, 2221-2227 (2008).

[15] Page, M. G.; Nassif, N.; Borner, H. G.; Antonietti, M.; Cölfen, H.: *Crystal Growth & Design* 8, 1792-1794 (2008).

[16] Cölfen, H.: In *Handbook of Biomaterialization: Biomimetic and Bioinspired Chemistry*, Behrens, P.; Baeuerlein, E., Eds. Wiley-VCH: Weinheim, 2007; pp 39-64.

[17] Cölfen, H.; Antonietti, M.: ed.; John Wiley & Sons: Chichester, 2008.

[18] Luo, Y. F.; Sonnenberg, L.; Cölfen, H.: *Crystal Growth & Design* 8, 2049-2051 (2008).

[19] Sonnenberg, L.; Luo, Y. F.; Schlaad, H.; Seitz, M.; Cölfen, H.; Gaub, H. E.: *Journal of the American Chemical Society* 129, 15364-15371 (2007).

[20] Fratini, E.; Page, M. G.; Giorgi, R.; Cölfen, H.; Baglioni, P.; Deme, B.; Zemb, T.: *Langmuir* 23, 2330-2338 (2007).

[21] Schwahn, D.; Ma, Y.; Cölfen, H.: *Journal of Physical Chemistry C* 111, 3224-3227 (2007).

[22] Kulak, A. N.; Iddon, P.; Li, Y.; Armes, S. P.; Cölfen, H.; Paris, O.; Wilson, R. M.: *Journal of the American Chemical Society* 129, 3729-3736 (2007).

[23] Xu, A.-W.; Antonietti, M.; Yu, S.-H.; Cölfen, H.: *Advanced Materials* 20, 1333-1338 (2008).

[24] Gebauer, D.; Völkel, A.; Cölfen, H.: *Science* 322, 1819-1822 (2008).

Polymer-Bioconjugates as Macromolecular LEGO®-Bricks



Hans G. Börner 15.09.1970

1996: Diploma, Chemistry

(Philipps-Universität Marburg)

Thesis: Applying the Concept of Large Counter Cations to Metal Free Anionic Polymerization of Acrylates and Meth Acrylates

1997-2000: Ph.D., Macromolecular

Chemistry (Philipps-Universität Marburg) Thesis: Synthesis of Novel Phosphine Substituted Block Copolymers and Application as Building Blocks for Nano Reactors

2000-2002: Postdoctoral Fellow

(Carnegie Mellon University, Pittsburgh, USA)

Since 2002: Group Leader

(Max Planck Institute of Colloids and Interfaces, Potsdam)

2009: Habilitation at the

University of Potsdam

Thesis: "Exploiting self-organization and functionality of peptides for polymer science"

References:

[1] Börner, H. G., Schlaad, H.: Bio-inspired functional block copolymers. *Soft Matter* **3**, 394-408, (2007).

[2] Lutz, J.-F., Börner, H. G.: Modern trends in polymer bioconjugates design. *Prog. Polym. Sci.* **33**, 1-39, (2008).

[3] Hartmann, L., Häfele, S., Peschka-Suess, R., Antonietti, M., Börner, H. G.: Tailor-made poly(amidoamine)s for controlled complexation and condensation of DNA. *Chem. Europ. J.* **2025-2033**, (2007).

[4] Dünne, A. A., Börner, H. G., Kukula, H., Schlaad, H., Werner, J. A., Wiegand, S., Antonietti, M.: Block copolymer carrier systems for translymphatic chemotherapy of lymph node metastases. *Anticancer Res.* **27**, 3935-3940, (2007).

[5] Schillinger, E.-K., Mena-Osteritz, E., Hentschel, J., Börner, H. G., Bäuerle, P.: Oligothiophene versus β -sheet peptide: Synthesis and self-assembly of an organic semiconductorpeptide hybrid. *Adv. Mater.* accepted, (2009).

The combination of monomer-sequence defined peptides and common synthetic polymers proved to result in an interesting class of multifunctional block copolymers. [1] These bioconjugates are referred to as peptide-polymer conjugates. [2] Prospectively, they are of importance for biomedical applications e.g. for drug delivery and bio-host systems, but also to realize functional nanostructures or nanoelectronics. [3-5] Peptide-polymer conjugates exhibit significantly different properties compared to amphiphilic or double hydrophilic block copolymers. [1] Most evident differences result from the monodisperse character of the peptide segment. The defined amino acid sequence of a peptide allows encoding specific information into bioconjugates. Besides programming the self-assembly properties, biological activity can be integrated. [6] Moreover, responsiveness to external stimuli, catalytic activity, molecular recognition and defined interaction capabilities to inorganic, or organic surfaces can be realized with peptide-polymer conjugates [7, 8]. The integration of such specific properties into synthetic polymer systems certainly enlarges the structural and functional space available for polymer science.

Methodologies to Synthesize Bioconjugates

In order to selectively introduce peptides into synthetic polymers new synthesis routes had to be evaluated. These include coupling strategies (1) and polymerization strategies (2). Further developments of the coupling route include the utilization of the copper catalyzed Huisgen 3+2 dipolar cycloaddition. The "click" reaction of alkyne and azide functional species results in robust protocols to conjugate peptides and polymers. [2] Besides these advances, the polymerization strategy was developed further. Prior work applied atom transfer radical polymerization (ATRP) to graft synthetic polymers from peptides. Recently, the reversible addition-fragmentation chain transfer polymerization (RAFT) process was applied successfully. This proved to be a versatile synthesis platform to access well-defined peptide-polymer conjugates with adjustable molecular weights and low polydispersity indices ($M_w/M_n \sim 1.1$). The approaches for that rely on both dithioesters and trithiocarbonates as peptide based chain transfer agents (peptide-CTAs). Kinetic investigations reveal that both types control the polymerization of various monomers. Particularly the trithiocarbonates have been evidenced to be robust against nucleophiles, making it expectable that these CTAs will be exploited further to synthesize complex bioconjugates.

Bioinspired Formation of Structure and Function

Recent progress in exploiting peptides and proteins for material science applications improved structural control in polymer self-assembly. This has been identified as one key requirement to develop nanochemistry and nanotechnology strategies.

While the generation of specific functions in bioconjugates (i.e. programming self-assembly) has been in the focus of prior work, the regulation of such functions get mandatory. For instance, the peptide-guided organization process of bioconjugates could be developed further by introducing a switch concept, allowing to control rates of aggregation. [9] The introduction of temporary structure defects (switch-esters) into a peptide can suppress the self-assembly. However, the undisturbed peptide could be reestablished by a pH triggered O→N acyl transfer rearrangement. This provides a handle to regulate the aggregation kinetics of bioconjugates in water and organic solvents. [10-12]

With respect to the design of potent regulative mechanisms, posttranslational modification principles of proteins possess an enormous potential. Based on this, a strategy was established that utilizes enzymes to specifically modulate properties of peptide segments in peptide-polymer conjugates (Fig. 1). [21]

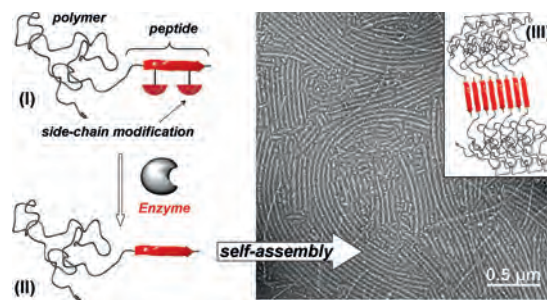

Fig. 1: Illustration of the BioSwitch process: Bioconjugate with suppressed aggregation tendency by O-phosphate modifications of threonine residues (I); enzymatic dephosphorylation activates the self-assembly tendency of the peptide (II), leading to fibrillar core-shell tapes (III, TEM micrograph stained with uranyl acetate).

To realize the BioSwitch process, a poly(ethylene oxide)-peptide (PEO-peptide) conjugate was synthesized that possesses a (valine-threonine)₅ aggregator domain. The introduction of phosphate moieties to the side chains of the threonine residues proved to disturb the peptide function and suppress the self-assembly process. Phosphatase could be applied to catalyze the hydrolysis of these phosphor monoesters. This restores the self-assembly tendency of the peptide segment and triggers the peptide-guided organization of the bioconjugate to form fibrillar structures (Fig. 1). It can be expected, that the BioSwitch process seed further research exploring the highly specific tools of molecular biochemistry to enzymatically switch, transform, or crosslink peptides.

Besides developing means to regulate self-assembly processes of bioconjugates, the established concepts could be exploited to organize organic semiconductor segments. [5]

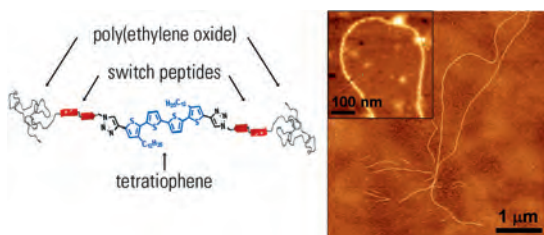

Fig. 2: Fibrillar “nanowires” formed by the directed self-assembly of a PEO-block-peptide-block-tetrathiophene-block-peptide-block-PEO ABA-conjugate (left). AFM micrograph of the fibrillar microstructures with the inset showing the left handed superhelical fine structure (right).

Functional microstructures could be obtained by combining a tetrathiophene segment with two PEO-peptide conjugates (Fig. 2). The ABA-bioconjugate was synthesized via click ligation and a controlled self-assembly process was assured by using the switch concept. AFM investigations of the assembled structures revealed the formation of fibrillar nanoobjects with several micrometers in length and suggest the presence of a left-handed superhelical fine structure. The bioinspired organic semiconductor system represents an initial example of a novel class of biomimetic materials, rendering well-ordered optoelectronic segments by self-assembly of biological moieties, eventually generating advanced function by structuring of materials.

Mimicking Biomaterials

Biological inorganic-organic materials e.g. from glass sponges are high performance, fiber directed composites. For instance, the glass sponge *Euplectella sp.*, one of the most primitive animals in existence, realizes integrated composite materials based on glass. This biological silica morphogenesis process could be mimicked by providing self-assembled peptide-polymer nanotapes as structural scaffolds to guide the condensation of silicic acid. As a result of an integrated self-assembly-silicification process, nanofiber-directed composite fibers formed spontaneously within seconds (Fig. 3b). Detailed analysis of the material reveals six distinguishable levels of hierarchical order and excellent mechanical properties.[7] The rapid process, which leads to structured composites could be exploited to generate on the one hand distinct silica nanocomposite tapes under kinetic conditions (Fig. 3a).[14] On the other hand a convenient 2D-plotting process could be established that enables one to draw macroscopic networks of nanostructured silica composite fibers (Fig. 3c).[15]

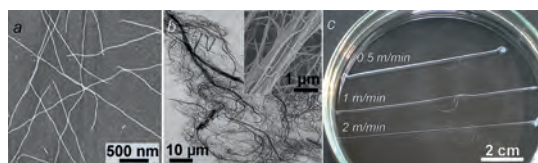

Fig. 3: Biomimetic silica composite fibers (AFM image of silica composite nanotapes (a), light microscopy and SEM micrographs of the macroscopic silica composite fibers (b & b, inset) and plotted biomimetic silica composites (c)).

Biological and Biomedical Applications

The development of defined peptide-polymer conjugates allows addressing pharmacological and biomedical issues.[4, 6, 16] On the one hand peptide-poly(*N*-isopropyl acrylamide) conjugates could be utilized to modify gold substrates.[6] This realizes surfaces with specific bioactivity, where the biological property could be reversible switched from cell attractant to cell repellent, depending on temperature.

On the other hand biocompatible carriers for drug delivery have been developed, e.g. to transport DNA for gene delivery applications. For that, a synthesis route to PEO-poly(amido amine) conjugates (PEO-PAA) was explored.[16] The strategy enables the synthesis of PEO-PAA conjugates with monodisperse PAA segments. Thus, the cationic character (balance and sequence of tert., sec., and prim. amine groups) can be programmed, making the fine tuning of the interaction capabilities of the carrier with plasmid DNA (*dsDNA*) feasible.[3, 17] PEO-PAA are well-defined model compounds, that exhibit low toxicity and sharp property profiles. This makes the class of precision polymers ideal to correlate e.g. the cationic balance of the PAA segments with the DNA complexation and compression properties as well as with membrane translocation and transfection activities.

Outlook

Bioconjugates and particularly peptide-polymer conjugates have been developed in the recent years to a multifunctional platform of precision polymers. The monodisperse character of the functional (pseudo)peptide segments allows for the precise definition of macromolecules and macromolecular properties. Thus, molecular toolboxes are provided to precisely define interaction capabilities, structure formation, and biological activity of interfaces. Moreover, the generation of distinct functions by positioning of functionalities can be achieved, which might drive research in various fields from nano-technology to biomedicine.

H. G. Börner, L. Hartmann, Y. Yagci, J. Hentschel, S. Kessel, H. Hahn; H. Kühnle; J. Brandt, K. Ostwald.
hans-boerner@mpikg.mpg.de

- [6] Hentschel, J., Bleek, K., Ernst, O., Lutz, J.-F., Börner, H. G.: Easy Access to Bioactive Peptide-Polymer Conjugates via RAFT Macromolecules **41**, 1073-1075, (2008).
- [7] Kessel, S., Thomas, A., Börner, H. G.: Mimicking biosilicification: programmed coassembly of peptide-polymer nanotapes and silica. *Angew. Chem., Int. Ed.* **46**, 9023-9026, (2007).
- [8] Page, M. G., Nassif, N., Börner, H. G., Antonietti, M., Cölfen, H.: Mesoporous calcite by polymer templating. *Cryst. Growth Des.* **8**, 1792-1794, (2008).
- [9] Hentschel, J., Börner, H. G.: Peptide-Directed Microstructure Formation of Polymers in Organic Media. *J. Am. Chem. Soc.* **128**, 14142-14149, (2006).
- [10] Hentschel, J., ten Cate, M. G. J., Börner, H. G.: Peptide-Guided Organization of Peptide-Polymer Conjugates: Expanding the Approach from Oligo- to Polymers. *Macromolecules* **40**, 9224-9232, (2007).
- [11] Hentschel, J., Börner, H. G.: Blendable Peptide-Polymer Nanofibers to Modulate Mechanical Properties of Polymers. *Macromol. Biosci.* **9**, accepted, (2009).
- [12] Hentschel, J., Krause, E., Börner, H. G.: Switch-peptides to Trigger the Peptide Guided Assembly of Poly(ethylene oxide)-Peptide Conjugates into Tape Structures. *J. Am. Chem. Soc.* **128**, 7722-7723, (2006).
- [13] Kühnle, H., Börner, H. G.: Biotransformation on Polymer-Peptide Conjugates – A Versatile Tool to Trigger Microstructure Formation. submitted, (2009).
- [14] Kessel, S., Börner, H. G.: High Rate Silicification of Peptide-Polymer Assemblies toward Composite Nanotapes. *Macromol. Rapid. Commun.* **29**, 419-424, (2008).
- [15] Kessel, S., Börner, H. G.: Self-Assembled PEO Peptide Nanotapes as Ink for Plotting Nonwoven Silica Nanocomposites and Mesoporous Silica Fiber Networks. *Macromol. Rapid. Commun.* **29**, 316-320 (2008).
- [16] Hartmann, L., Börner, H. G.: Precision Polymers: Monodisperse, monomer-sequence defined segments to target future demands of polymers in medicine. *Adv. Mater.* (2009).
- [17] Hartmann, L., Haefele, S., Peschka-Suess, R., Antonietti, M., Börner, H. G.: Sequence Positioning of Disulfide Linkages to Program the Degradation of Monodisperse Poly(amidoamines). *Macromolecules* **40**, 7771-7776, (2007).

Bioinspired Polymers and Colloids

Polymers: Synthesis

The radical addition of thiols onto 1,2-polybutadiene is a versatile route for the generation of a toolbox of functional polymers [4, 10, 17, 19]. Thiyl radicals can be produced via a radical source at elevated temperature or directly through irradiation with UV light or sunlight [16]. The degree of functionalization is usually less than quantitative, which is due to a side reaction of the intermediate radical species leading to the formation of six-member cycles along the polymer backbone. Such side reaction can be avoided when 1,2-polybutadiene is replaced by poly[2-(3-butenyl)-2-oxazoline] (Fig. 1). The modification of the poly(oxazoline) with thiol has the characteristics of a "click" reaction, enabling the synthesis of highly hydrophobic fluoropolymers in the same way as that of water-soluble glycopolymers [7, 11, 18].

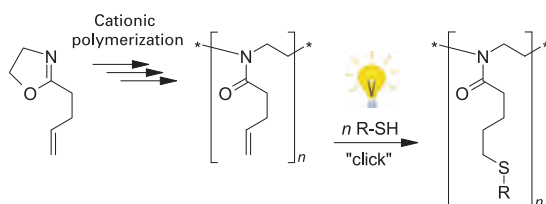

Fig. 1: Synthesis and click modification of poly[2-(3-butenyl)-2-oxazoline].

Colloids: Polyoxazolines

Annealing of an dilute aqueous solution of poly(2-isopropyl-2-oxazoline) above its cloud point leads to the formation of coagulate in the form of crystalline nanofibers (Fig. 2) with a melting point of about 195°C. Directional crystallization, which occurs below the glass transition of the polymer at 65°C, is driven by hydrophobic and dipolar interactions in combination with a solvation effect [3, 8].

Glycosylated polyoxazoline homopolymers, consisting of a hydrophilic tertiary polyamide backbone and hydrophilic D-glucose side chains, can self-assemble into spherical vesicles and nanofibers upon direct dissolution in water. Based on transmission electron and scanning force microscopy and small-angle X-ray scattering data, it is proposed that nanofibers are hollow nanotubes with a cross-sectional radius of less than 10 nm and a wall having a thickness of about 1 nm. As evidenced by spectroscopy, the wall should be constructed of chains forming a sheet through intermolecular hydrogen bonding between amide and glucose units (Fig. 3) [11, 18].

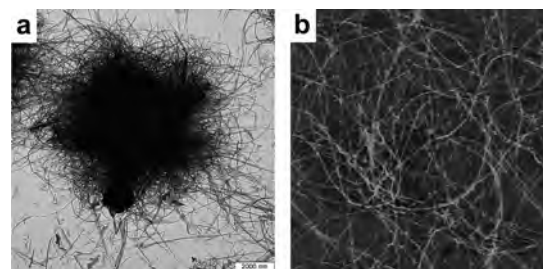

Fig. 2: (a) Transmission electron image of coagulate particles produced by poly(2-isopropyl-2-oxazoline) in pure water (scale bar = 2 μm). b) SFM topography image (10 × 10 μm²) of the coagulate formed under stirring in a mixture of water and tetrahydrofuran 98:2 (v/v) within 24 h at 65°C.

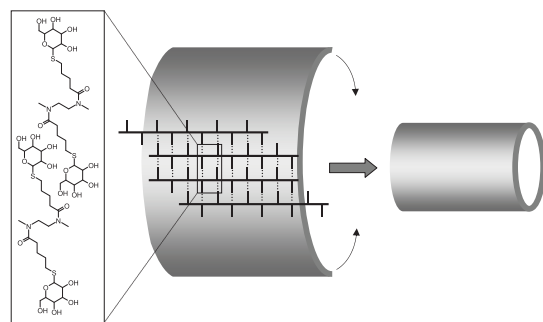

Fig. 3: Tentative idealized structure of the hydrogen-bonded glycosylated polyoxazoline layer (hydrogen bonds are indicated as dotted lines) and subsequent bending and closing into a nanotube.

Helmut Schlaad 04.08.1967

1993: Diploma, Physical Chemistry (University of Mainz)

Thesis: Studies of the Anionic Polymerization of Methyl Methacrylate in Toluene in the Presence of Aluminium Alkyls

1997: PhD, Physical Chemistry (University of Mainz)

Thesis: Studies of the Mechanism of the Anionic Polymerization of Methacrylates in the Presence of Aluminium Alkyls in Toluene

1998: Postdoc (University of Massachusetts, Lowell, USA)

Since 1999: Group Leader

(Max Planck Institute of Colloids and Interfaces, Potsdam)

Since 2004: Senior Scientist

(Max Planck Institute of Colloids and Interfaces, Potsdam)

2004: Habilitation, Physical Chemistry (University of Potsdam)

Thesis: Polymer Self-Assembly: Adding Complexity to Messtructures of Diblock Copolymers by Specific Interactions

References:

- [1] I. Voets, A. de Keizer, M.A. Cohen Stuart, J. Justynska, H. Schlaad: Irreversible structural transitions in mixed micelles of oppositely charged diblock copolymers in aqueous solution. *Macromolecules* **40**, 2158-2164 (2007).
- [2] H.G. Börner, H. Schlaad: Bioinspired functional block copolymers. *Soft Matter* **3**, 394-408 (2007).
- [3] M. Meyer, M. Antonietti, H. Schlaad: Unexpected thermal characteristics of aqueous solutions of poly(2-isopropyl-2-oxazoline). *Soft Matter* **3**, 430-431 (2007).
- [4] Z. Hordyjewicz-Baran, L. You, B. Smarsly, R. Sigel, H. Schlaad: Bioinspired polymer vesicles based on hydrophilically modified polybutadienes. *Macromolecules* **40**, 3901-3903 (2007).
- [5] R. Sigel, M. Losik, H. Schlaad: pH Responsiveness of block copolymer vesicles with a polypeptide corona. *Langmuir* **23**, 7196-7199 (2007).

Colloids: Polypeptides

Combined dynamic and static light scattering was applied to study the vesicles of polybutadiene₁₆₅-*block*-poly(L-lysine)₈₈ in dilute saline solution at pH 7.0 (polypeptide in 100% coil conformation) and pH 10.3 (polypeptide in 80% α -helical conformation). At the higher pH, the vesicles were considerably smaller in size (hydrodynamic radius: 364 nm \rightarrow 215 nm) and chains were more densely packed at the core-corona interface (inter-chain distance, b : 3.2 nm \rightarrow 2.4 nm) (**Fig. 4**). Changes in size and structure can be explained in basic terms of colloid stabilization without considering any secondary structure effect [5].

Structure formation in solutions of a polystyrene₆₃-*block*-{poly(γ -benzyl-L-glutamate)₃₇}₈ hetero-arm star block copolymer, obtained by swelling thin films in chloroform solvent vapor, were investigated by optical and scanning force microscopy (SFM). Direct observation by optical microscopy revealed the nucleation and growth of ordered three-dimensional structures of ellipsoidal shape (**Fig. 5**). The process of structure formation is considerably affected by the presence of water. The observed effect is attributed to changes in the solubility of the polymer in chloroform due to a complexation of water molecules with the α -helical polypeptide chains [12].

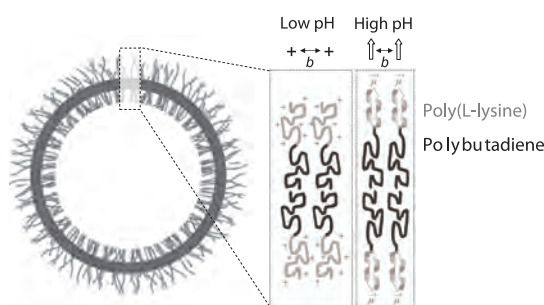

Fig. 4: Tentative structures of PB₁₆₅-*b*-PLLys₈₈ vesicles at different pH.

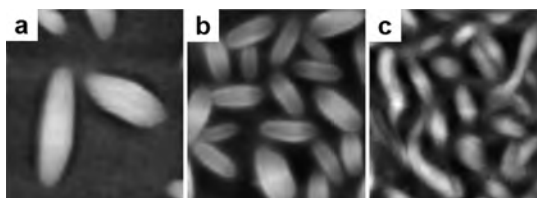

Fig. 5: SFM topography images ($2.5 \times 2.5 \mu\text{m}^2$) of the ellipsoidal structures formed in solutions of polystyrene₆₃-*block*-{poly(γ -benzyl-L-glutamate)₃₇}₈ in chloroform at different concentrations: a) 53%, b) 55%, c) 57%.

H. Schlaad, J. Brandt, M. Gräwert, A.L. Demirel, A. Bertin, Z. Hordyjewicz-Baran, L. You, A. Gress, F. Hermes, C. Diehl, N. ten Brummelhuis, helmut.schlaad@mpikg.mpg.de

[7] A. Gress, A. Völkel, H. Schlaad: Thio-click modification of poly[2-(3-butenyl)-2-oxazoline]. *Macromolecules* **40**, 7928-7933 (2007).

[8] A.L. Demirel, M. Meyer, H. Schlaad: Formation of polyamide nanofibers by directional crystallization in aqueous solution. *Angew. Chem. Int. Ed.* **46**, 8622-8624 (2007).

[9] L. Sonnenberg, Y. Luo, H. Schlaad, H. Cölfen, M. Seitz, H.E. Gaub: Quantitative single molecule measurements on the interaction forces of poly(L-glutamic acid) with calcite crystals. *J. Am. Chem. Soc.* **129**, 15364-15371 (2007).

[10] J.-F. Lutz, H. Schlaad: Modular chemical tools for advanced macromolecular engineering. *Polymer* **49**, 817-824 (2008).

[11] A. Gress, B. Smarsly, H. Schlaad: Formation of glycopolyamide nanofibers. *Macromol. Rapid Commun.* **29**, 304-308 (2008).

[12] I. Botiz, N. Grozev, H. Schlaad, G. Reiter: The influence of protic non-solvents present in the environment on structure formation of poly(γ -benzyl-L-glutamate) in organic solvents. *Soft Matter* **4**, 993-1002 (2008).

[13] C. Koňák, V. Šubr, L. Kostka, P. Štěpánek, K. Ulbrich, H. Schlaad: Coating of vesicles with hydrophilic reactive copolymers. *Langmuir* **24**, 7092-7098 (2008).

[14] A.L. Demirel, H. Schlaad: Controlling the morphology of polybutadiene-poly(ethylene oxide) diblock copolymers in bulk and the orientation in thin films by attachment of alkyl side chains. *Polymer* **49**, 3470-3476 (2008).

[15] G. Orts Gil, M. Łosik, H. Schlaad, M. Drechsler, T. Hellweg: Properties of pH-responsive mixed aggregates of polystyrene-*block*-poly(L-lysine) and nonionic surfactant in bulk solution and adsorbed at a solid interface. *Langmuir* **24**, 12823-12828 (2008).

[16] N. ten Brummelhuis, C. Diehl, H. Schlaad: Thiolene modification of 1,2-polybutadiene using UV light or sunlight. *Macromolecules* **41**, 9946-9947 (2008).

[17] L. You, PhD thesis, University of Potsdam, 2007.

[18] A. Gress, PhD thesis, University of Potsdam, 2008.

[19] Z. Hordyjewicz-Baran, PhD thesis, University of Potsdam, 2008.

Fractionating Colloid Analytatics



Helmut Cölfen 24.07.1965
1991: Diploma, Physical Chemistry (University of Duisburg)
 Thesis: Analytical Ultracentrifugation of Gels
1993: PhD, Physical Chemistry (University of Duisburg)
 Thesis: Analytical Ultracentrifugation of Gels
1993-1995: Postdoc (National Center for Macromolecular Hydrodynamics, University of Nottingham)
Since 1995: Group Leader (Max Planck Institute of Colloids and Interfaces, Potsdam)
2001: Habilitation, Chemistry (University of Potsdam)
 Thesis: Biomimetic Mineralisation Using Hydrophilic Copolymers: Synthesis of Hybrid Colloids with Complex Form and Pathways towards their Analysis in Solution
Since 2004: Private Docent; University of Potsdam

Analytical Ultracentrifugation (AUC) is a powerful fractionating analysis method for colloids and polymers. AUC is available as an active service unit for a large variety of colloid and polymer analysis problems from the institute and is used in multiple studies which are not cited here. We follow three main working directions in this project: a) detector development, b) method development c) colloid and polymer characterization. For the latter it was laid special emphasis on complex polymer and colloid systems, which can not be characterized by other analytical methods with the same information content.

We have developed the methodology to characterize the osmotic pressure of solutions or swelling pressure of gels by AUC further, to include the determination of the equation of state of liquid crystalline systems via osmotic pressure measurements in sedimentation equilibrium. [1] These measurements include the determination of phase boundaries, which are very difficult to obtain otherwise. For laponite clay dispersions, it could be demonstrated that a continuous dependence of the osmotic pressure, over orders of magnitude between at least $\sim 10^1$ and 10^4 Pa, and a wide concentration range, can be determined in agreement with standard theoretical considerations in one experiment. Two regimes – counter-ion ideal gas and interacting double layers – can be easily identified in the equation of state, whereas meta-stable glass- or microphase-separated gel states previously encountered in osmotic stress measurements of laponite are circumvented. [1] Fig. 1 shows the good agreement of the measured osmotic pressures with those derived from theoretical models for the dilute and concentrated regime. These results show the advantage of the AUC experiment, which yields hundreds of osmotic pressure concentration pairs over the traditional time consuming osmotic stress approach which yields only a single data pair. Also the possibility to investigate multiphase systems and phase boundaries in a single experiment demonstrates the power of the approach.

The ultracentrifuge can also be applied to separate samples according to their density by the established technique of density gradient ultracentrifugation. Although density gradient techniques have been well-established for decades to separate various biopolymers from mixtures or biopolymers with subtle density differences like single- and double-stranded DNA, the methodology can still be developed – in our case for the separation of racemates from pure enantiomers (Fig. 2).

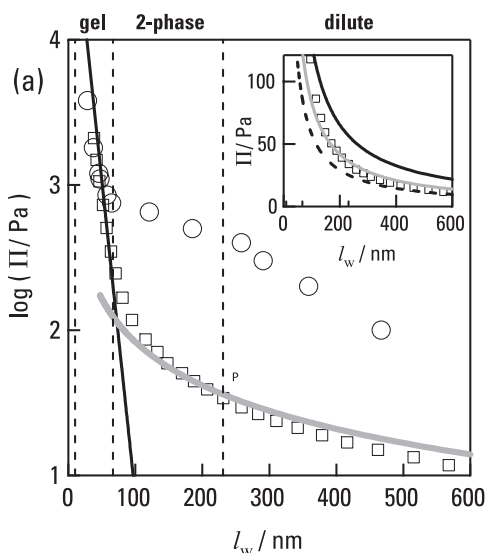

Fig. 1: Osmotic pressure (log scale) plotted against water layer thickness, l_w , for disc-like laponite RD particles of thickness 1 nm and diameter 25 nm. Open squares: AUC experimental data; open circles: literature experimental data from osmotic stress experiments. Solid line in the high and low concentration regime: theoretical osmotic pressure. Vertical lines delineate the literature-determined phase boundaries at $l_w = 67$ and 230 nm, and the Debye length for 10^{-3} M salt, of ~ 10 nm. Inset: The experimental data in the low-concentration regime, and the calculated osmotic pressure for average particle diameters of 20 nm (solid black line), 25 nm (grey line) and 30 nm (dashed black line), shown on a linear scale.[1]

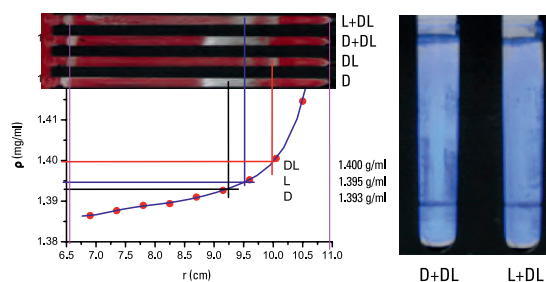

Fig. 2: Separation of DL-alanine crystals from the pure enantiomer crystals by density gradient ultracentrifugation in a Nycodenz gradient. The left figure (upper) shows the bands in the ultracentrifuge tubes and the lower part shows the corresponding calibration curve which allows the determination of the sample density. The right figure shows the separation of L- resp. D-alanine (upper band at meniscus) from the denser racemate (lower band) with a Nycodenz solution with intermediate density [2].

This separation is based on the fact that solid racemic compounds differ significantly in density from the corresponding pure enantiomers. This difference can be as large as 5 %. The racemic compounds in the solid state are denser than the corresponding enantiomers so that pure enantiomers can be separated from racemates even on a preparative scale by density gradient ultracentrifugation. [2] Fig. 2 shows that the bands for the different compounds can be clearly separated although the density difference between them is very small and in the third decimal digit. This shows that the density accuracy is high and in the third digit in density while also good recovery rates between 75 and 90 % are achieved. [2] This procedure is a simple method for the separation of enantiomers from racemates, which so far is only possible by expensive methods.

The third focus of our work was the further development of the multiwavelength detector for the AUC. [3] We have carried out systematic performance tests and found that our detector prototype yields data of a similar or better quality than the commercial Beckman XL-A instrument, although a whole range of wavelengths is acquired instead of a single wavelength as in the commercial instrument (for an experimental scan see Fig. 3). The multiwavelength detector is now in a stage to become applicable for routine operation.

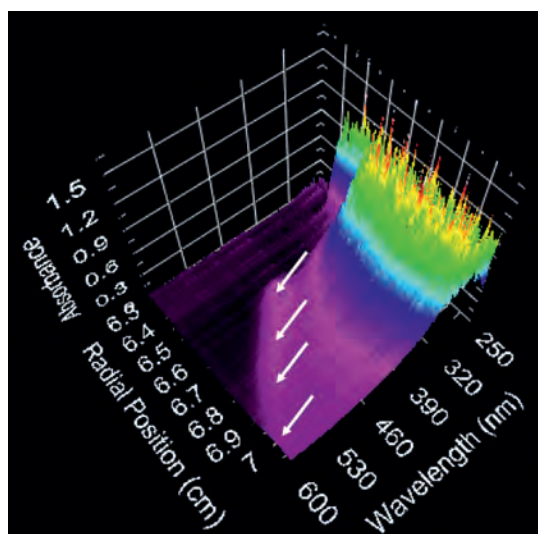

Fig. 3: Raw scan from the multiwavelength detector for the AUC on a CdTe nanoparticle sample. The blue shift of the absorption maximum (white arrows) with decreasing particle size at decreasing radial distance is visible. Sedimentation proceeds towards higher radii.

First experiments demonstrate the virtue of this detector, which is able to continuously measure size dependent optical properties of colloids. One example is shown in Fig. 3 where CdTe quantum size nanoparticles were separated in the AUC according to the particle size (proportional to the radial position in the shown raw data). Already in the raw data, the blue shift of the absorption maximum (white arrows) with decreasing size (radial position) is obvious. This enables a few hundred correlations of size dependent optical properties in a single sedimentation velocity experiment lasting a few hours. It has to be emphasized that Fig. 3 just shows unprocessed raw data from a single time scan in the multiwavelength AUC. This indicates the gain in information content from AUC data, which can be achieved with this detector. We will now start to use this detector technology for the determination of size dependent optical properties of various colloids and start its use for routine operation in the AUC service unit in the institute.

H. Cölfen, E. Karabudak, M.G. Page, H.M. Strauss, A. Völkel, Coelfen@mpikg.mpg.de

References:

- [1] Page, M. G.; Zemb, T.; Dubois, M.; Cölfen, H.: Osmotic Pressure and Phase Boundary Determination of Multiphase Systems by Analytical Ultracentrifugation. *ChemPhysChem* **9**, 882-890 (2008).
- [2] Mastai, Y.; Völkel, A.; Cölfen, H.: Separation of Racemate from Excess Enantiomer of Chiral Nonracemic Compounds via Density Gradient Ultracentrifugation. *Journal of the American Chemical Society* **130**, 2426-2427 (2008).
- [3] Strauss, H. M.; Karabudak, E.; Bhattacharyya, S.; Kretzschmar, A.; Wohlleben, W.; Cölfen, H.: Performance of a fast fiber based UV/Vis multiwavelength detector for the analytical ultracentrifuge. *Colloid and Polymer Science* **286**, 121-128 (2008).

Electron Microscopic Studies of Colloidal Systems and Biomaterials



Jürgen Hartmann 18.10.1953

1977: Diploma, Physics

(Humboldt University Berlin; Institute of Low-Temperature Solid State Physics)

Thesis: Application of Square-Wave Polarography and a Density Method for the Analysis of Bismuth-Antimony Alloys

1977–1991: Research Scientist

(Institute for Polymer Chemistry, Teltow)

1987: PhD, Polymer Physics

(Institute of Polymer Chemistry, Teltow)

Thesis: Contribution to the Formation Mechanism of Coagulation Structures of Polymers Using Electron Microscopy

1992–1995: Research Scientist

(Max Planck Institute of Colloids and Interfaces, Potsdam)

Since 1995: Group Leader

(Max Planck Institute of Colloids and Interfaces, Potsdam)

Transmission, high-resolution scanning and environmental electron microscopy are suitable tools to investigate the morphological structure of polymer micelles and particles, organic and inorganic crystals and nanoparticles, fibers, aggregates of biopolymers, polyelectrolyte complex shells, composite materials and naturally-grown biomaterials.

Because of the organization of the institute, there is a close cooperation with a number of research groups of the colloid chemistry, interface and biomaterials departments and the University of Potsdam. On the other hand, the electron microscopy lab is a so called central service lab to perform scientific routine measurements for the whole institute. Selected interesting results are presented here.

Basically polymers exhibit critical solution behavior dependent on temperature, simply because of the thermodynamics of polymer-solvent interactions.

A critical solution behavior could be observed for quite a number of polymers. Especially in biomedical applications the temperature at which a polymer becomes insoluble should be close to human body temperature and relatively insensitive to changes in environmental conditions. The lower critical solution temperature of poly(2-isopropyl-2-oxazoline) (PIPOX) can be triggered in a wide temperature range (-30 – 80°C) by changing concentration and molecular weight as well as by adding salts and surfactants.

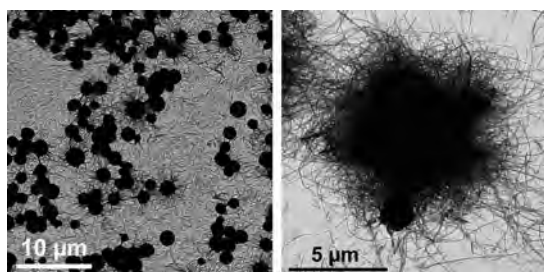

Fig. 1: Dried coagulate particles formed by PIPOX_{47}^{+} in water through annealing for 24 h at 65°C .

Annealing of dilute aqueous solutions of PIPOX at above the cloud point leads to the irreversible formation of coagulate particles with hierarchical ordering on two length-scales.

Fig. 1 shows exemplarily transmission electron micrographs of the dried coagulate produced by PIPOX_{47}^{+} in water at $\text{pH}\sim 6.5$. The concentration of polymer was 0.05% by weight. One can see two types of structures on two different levels of length-scale, namely micron-sized spherical particles together with fibrils having a cross-sectional diameter of about 30–50 nm and a length of several microns. The microspheres are amazingly uniform in size and shape. They are densely packed and actually built of these fibrillar aggregates. Neither the inner structure of PIPOX fibrils nor the mechanism of self-assembly of fibrils into spheres is known yet. Further investigations by solid-state NMR and electron diffraction experiments as well as by time-resolved imaging shall be performed to gain a better understanding of this self-organization process.

Another interesting subject is the synthesis of functional silica-based materials, enabling one to conveniently draw nanostructured, macroscopic networks of oriented silica composite fibers, which can be used as precursors for fabrics of mesoporous silica fibers. Studies addressed the control of hierarchical nano- and microstructures, porosity, chirality as well as surface functionality. By using self-assembled PEO-peptide nanotapes as an ink to draw the composite fibers, the macroscopic form of the fiber networks, the line width, and both network orientation as well as network anisotropy can be defined. The local injection of PEO-peptide nanotapes into a thin layer of a dilute solution of pre-hydrolyzed TMOS leads to a rapid formation of the composite fibers, which exhibit several levels of hierarchical order. The rate of plotting is a parameter, enabling one to control the line width and the orientation of the nano- and sub-micrometer structure elements in the network.

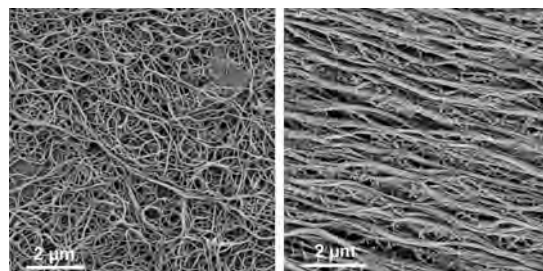

Fig. 2: Silica composite fiber morphology, plotted with different rates of $0.5 \text{ m} \cdot \text{min}^{-1}$ (left) and $2 \text{ m} \cdot \text{min}^{-1}$ (right).

Fig. 2 shows the morphological structure of silica composite fibers, plotted with a constant rate of nanotape injection ($0.2 \text{ mL} \cdot \text{min}^{-1}$, 4 mg nanotapes per min) at different plotting rates. Interestingly, rather flat, fiber structures are generated. Due to the cooperative nature of the composite fiber formation, both the silicification and the self-assembly processes strongly depend on the rate of silicic acid influx to the places of composite fiber formation. However, the well-defined width and sharp boundaries of the composite macrofibers suggest that indeed a critical cross-link density is reached rapidly, preventing axial diffusion of the nanotapes (e.g. **Fig. 2** left). The SEM micrographs show a homogeneous network, composed of rather uniform fiber elements with diameter of about 60 to 100 nm. Moreover, the same complex structure and corresponding levels of hierarchical order are evident, suggesting that the formation of the plotted and batch composite fibers occurs via analogous silicification self-assembly processes.

Acoustic waves with higher frequencies interacting with a species can cause structural changes and accelerate chemical reactions. The majority of sonochemical reactions in aqueous solutions applying acoustic vibrations is caused by cavitation. To examine the influence of ultrasonic treatment on the activity and crystalline structure, Pt nanoparticles were sonicated e.g. in water.

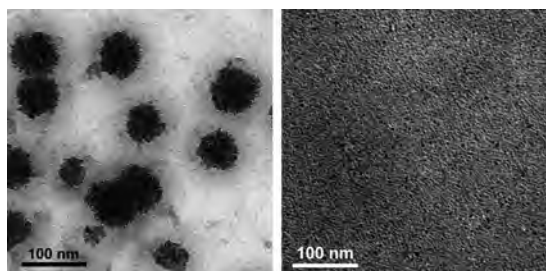

Fig. 3: TEM micrographs of platinum nanoparticles before (left) and after 60 min sonication in water (right).

They were stabilized with citrate ions, resulting in assemblies of spherical shape (Fig. 3 left). The size of preformed Pt nanoparticles assemblies is varying from 50 nm to 80 nm in diameter. After 1 h of ultrasonic treatment a complete decomposition of these Pt assemblies was observed and only small Pt nanoparticles in the range of 3 nm to 6 nm were obtained (Fig. 3 right). In this case very interesting opposite effects on the crystalline structure, depending on sonication time, were found for Pt nanoparticles.

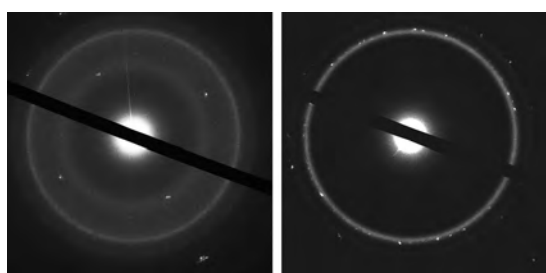

Fig. 4: Electron diffraction pattern of platinum nanoparticles before (left) and after 60 min sonication in water (right).

Both thin sharp and diffuse rings with several spots were observed in the diffraction pattern of the Pt nanoparticles before sonication (Fig. 4 left). Diffuse rings are due to small platinum grains, whereas the sharp ones are mainly ascribed to their assemblies. The presence of bright sharp dots points to the specific orientation of small platinum seeds. Narrow diffraction rings were turned found for Pt nanoparticles after ultrasonic treatment for 1 h (Fig. 4 right). The change from diffuse to sharp rings is characteristic of recrystallization of the platinum nanoparticles.

Another important project is the electron microscopic characterization of highly ordered arrays of metallic Au nanostructures. Monodisperse polymer spheres of submicrons to microns in size can readily self-assemble into ordered and closepacked arrays on the surfaces of the substrate. Using angle-resolved colloidal lithography and O_2 -plasma etched bilayers of hexagonally packed spheres as templates, well ordered arrays of gold nanoparticles with different shapes are formed. The size and shape of Au nanoparticles obtained can be manipulated by the plasma etching period and the incidence angle of Au vapor flow. The subsequent thermal annealing at 900 °C for 60 min in ambient led to hexagonally arranged arrays of small and big Au nanoparticles with a nearly round shape (Fig. 5). Prior to Au vapor deposition, the bilayers of hexagonally close-packed 830 nm PS spheres were etched by O_2 -plasma for different time periods. Subsequently, they were used as masks for Au vapor deposition at the incidence angle of 15°. After decomposition of the PS bilayer masks with toluene, the resulting Au nanostructures are investigated by scanning electron microscopy.

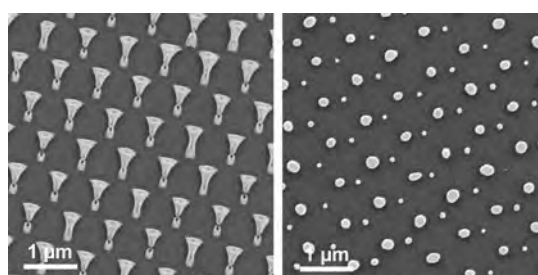

Fig. 5: Hexagonally arranged Au nanoshuttlecocks obtained by using bilayers of hexagonal close-packed PS spheres, etched by O_2 -plasma for 25 min (left). Hexagonal binary arrays obtained by annealing the nanoshuttlecock arrays (right).

The periodicity remained little varied, about 830 nm. This approach should pave a versatile colloidal way to form binary nanoparticle arrays for technical applications such as nanoelectronics and nanophotonics.

J. Hartmann, H. Schlaad, H.G. Börner, D. Wang, G. Zhang, D. Radziuk, D. Shchukin
juergen.hartmann@mpikg.mpg.de

References:

- [1] Polarz, S., Regenspurger, R., Hartmann, J.: Self-assembly of methyl-zinc-polyethylene glycol amphiphiles and their application to material synthesis. *Angewandte Chemie-International Edition* **46** (14): 2426-2430 (2007).
- [2] Sapei, L., Gierlinger, N., Hartmann, J., Nöske, R., Strauch, P., Paris O.: Structural and analytical studies of silica accumulations in *Equisetum hyemale*. *Anal. Bioanal. Chem.* **389**:1249-1257. (2007)
- [3] Zhang, H., Wang, D., Hartmann, J., Möhwald, H.: Environment-Induced Structure Change of As-Prepared Aqueous CdTe Nanocrystals. *J. Phys. Chem. C* **111**, 9678-9683 (2007).
- [4] Rautengarten, C., Usadel, B., Neumetzler, L., Hartmann, J., Büssis, D. and Altmann, T.: A subtilisin-like serine protease essential for mucilage release from *Arabidopsis* seed coats. *The Plant Journal* **54**, 466-480 (2008).
- [5] Ebert, B., Zoeller, D., Lieckfeldt, E., Erban, A., Fehrle, I., Hartmann, J., Niehl, A., Kopka, J., Fisahn, J.: The differentiated metabolic phenotype of epidermal cell types in *Arabidopsis thaliana*. Submitted to *The Plant Journal* (2008).
- [6] Shkilnyy, A., Gräf, R., Hiebl, B., Nefte, A., Friedrich, A., Hartmann, J., Taubert, A.: Unprecedented Low Cytotoxicity of Spongeliike Calcium Phosphate/Poly(ethylene imine)Hydrogel Composites. Submitted to *Macromol. Biosci.* (2008).

From Hard to Soft Porous Frameworks



Nanostructured materials have been subject of recent study because of their unusual mechanical, electrical and optical properties which arise from confinement effects and the combined properties of bulk and surface. One challenge crucial for applications like catalysis, sensing or separation is the control of the functionality, nano- and macrostructure of these materials. Our group is investigating materials that combine these features with the main focus on the preparation of materials with pores of nano-sized dimensions. Several materials are under investigation ranging from "hard" inorganic materials to "soft" organic materials.

Arne Christian Thomas 07.04.1975

2001: Diploma, Chemistry

(Philipps-Universität Marburg)

Thesis: Synthesis of cholestric cellulose derivatives with covalently bonded chromophores and investigation of their optical properties

2003: PhD, Chemistry

(Universität Potsdam)

Thesis: Mesoporous silicas by nanocasting – from chiral templates to a new chemistry in pores

2004-2005: Postdoc

(University of California,

Santa Barbara, USA)

Since 2005: Group Leader

(Max Planck Institute of Colloids and Interfaces, Potsdam)

References:

[1] Thomas, A.; Fischer, A.; Goettmann, F.; Antonietti, M.; Müller, J. O.; Schlogl, R.; Carlsson, J. M.: Graphitic carbon nitride materials: variation of structure and morphology and their use as metal-free catalysts. *J. Mater. Chem.* **41**, 4893-4908, (2008).

[2] Bojdys, M. J.; Müller, J. O.; Antonietti, M.; Thomas, A.: Ionothermal Synthesis of Crystalline, Covalent, Graphitic Carbon Nitride. *Chem. Eur. J.* **14**, 8177-8182, 2008

[3] Fischer, A.; Antonietti, M.; Thomas, A.: Growth confined by the nitrogen source: Synthesis of pure metal nitride nanoparticles in mesoporous graphitic carbon nitride. *Adv. Mater.* **2**, 264-267, (2007).

[4] Fischer, A.; Jun, Y. S.; Thomas, A.; Antonietti, M.: Synthesis of High-Surface-Area TiN/Carbon Composite Materials with Hierarchical Porosity via "Reactive Templating". *Chem. Mater.* **24**, 7383-7389, (2008).

[5] Fischer, A.; Müller, J. O.; Antonietti, M.; Thomas, A.: Synthesis of Ternary Metal Nitride Nanoparticles Using Mesoporous Carbon Nitride as Reactive Template. *ACS Nano* **12**, 2489-2496, (2008).

Carbon Nitrides

Graphitic carbon nitrides ($g\text{-C}_3\text{N}_4$) can be prepared by thermal condensation of simple precursors like dicyandiamide or melamine **[1]**. Following a reaction/condensation scheme the resulting materials adopt a structure characterized by graphitic stacking of layers composed of interlinked heptazine units. New synthetic conditions for carbon nitride materials are explored, e.g. temperature induced condensation of dicyandiamide in salt melts as a solvent, yielded highly crystalline, graphitic carbon nitride, which is expressed in the formation of macroscopic crystals in the form of hexagonal prisms **[2]**.

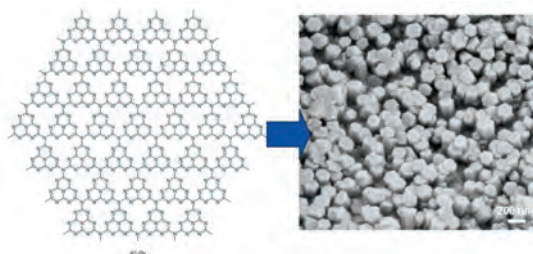

Fig. 1: The schematic internal structure of $g\text{-C}_3\text{N}_4$ is reflected in the crystal morphology. SEM images of crystalline graphitic carbon nitride prepared in molten salt show hexagonal prisms.

Metal Nitrides

Metal nitrides have considerable prospects as catalysts or optoelectronic materials, however in contrast to their corresponding metal oxides, a general synthetic strategy for the control of their nanostructure, porosity and surface area was not envisaged yet. Using an approach called "Reactive Templating", metal nitrides with variable nanostructure and composition can be prepared **[3-5]**. In this approach nanostructured carbon nitrides are used as both, a template and a nitrogen source yielding the metal nitride. The so-prepared metal nitrides exhibit high surface areas and a remarkable activity as catalytic materials **[6]**.

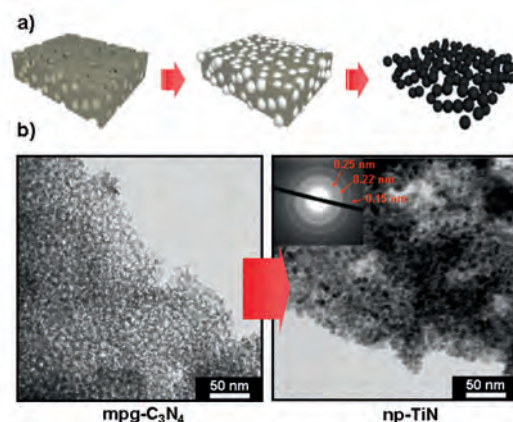

Fig. 2 a) Scheme of the "reactive templating" approach for the synthesis of metal nitride nanoparticles from mesoporous graphitic carbon nitrides b) TEM micrograph of mpg- C_3N_4 , and titanium nitride nanoparticles generated there from.

Self-Assembled Microporous Polymers

Polymers with highly rigid and contorted molecular structures prevent space-efficient packing in the solid-state and can consequently exhibit microporosity. Recently, we were able to apply this concept to common polymers like aromatic poly(imide)s or poly(amide)s [7]. A desirable motif that prevents space-efficient packing or crystallization is a 90° kink within the polymer chain, for example provided by difunctionalized spirobifluorens. Soluble aromatic polyimides exhibiting high surface areas in their solid state have been synthesized using this structure directing motif.

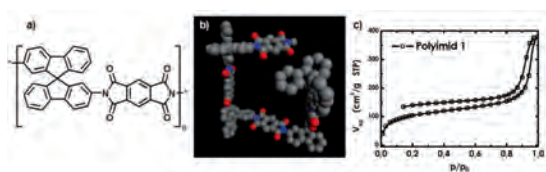

Fig. 3: a) Chemical structure of a microporous polyimide generated by incorporation of spirouinits into the polymer chain. b) Calculated conformation of Polyimide 1 c) Nitrogen sorption isotherm for PI-1

A similar concept was used for the formation of microporous cross-linked polymer networks yielding polymers with surface areas of more than 1000 m²/g [8]. Also networks composed of conjugated polymers, for example based on polypara-phenylenes or polythiophenes have been produced [9-10].

Organic Frameworks

Combining classical elements of the synthesis of inorganic materials and (organic) polymerizations, the synthesis of highly porous, covalent organic frameworks have been achieved by carrying out trimerization reactions of dicyanocompounds in molten zinc chloride [11]. Using the suitable reaction conditions, which enable a dynamic, reversible trimerization reaction of the carbonitriles, triazine-based covalent organic frameworks with high surface areas could be produced. Further heat treatment even produced materials with surface areas of more than 3000 m²/g [12-14].

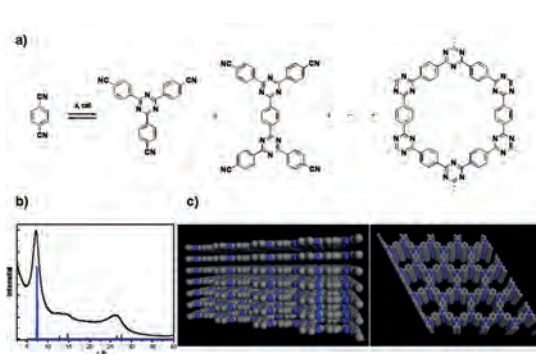

Fig. 4: a) Schematic presentation of the trimerization reaction of dicyanobenzene into a covalent triazine-based framework (CTF-1). b) Experimental (black) and calculated (blue) WAXS diffractogram of a triazine network made from 1,4-dicyanobenzene. c) Schematic representation of the structure of CTF-1.

Compared to other widely used catalyst-support materials, such as activated carbons these frameworks provide a high amount of selective binding sites for metals and thus have extraordinary prospects as catalyst support material as well as for hydrogen or methane storage materials.

A. Thomas, M. J. Bojdys, A. Fischer, A. Ide, P. Kuhn, P. Makowski, J.P. Paraknowitsch, N. Ritter, J. Schmidt, J. Weber
arne.thomas@mpikg.mpg.de

- [6] Fischer, A.; Makowski, P.; Müller, J. O.; Antonietti, M.; Thomas, A.; Goettmann, F.: High-Surface-Area TiO₂ and TiN as Catalysts for the C-C Coupling of Alcohols and Ketones. *ChemSusChem* **5**, 444-449, (2008).
- [7] Weber, J.; Su, O.; Antonietti, M.; Thomas, A.: Exploring polymers of intrinsic microporosity-microporous, soluble polyamide and Polyimide. *Macromol. Rap. Commun.* **18-19**, 1871-1876, (2007).
- [8] Weber, J.; Antonietti, M.; Thomas, A.: Microporous networks of high-performance polymers: Elastic deformations and gas sorption properties. *Macromolecules* **8**, 2880-2885, (2008).
- [9] Weber, J.; Thomas, A.: Toward Stable Interfaces in Conjugated Polymers: Microporous Poly(p-phenylene) and Poly(phenyleneethynylene) Based on a Spirobifluorene Building Block. *J. Amer. Chem. Soc.* **20**, 6334-6335, (2008).
- [10] Schmidt, J.; Weber, J.; Epping, J. D.; Antonietti, M.; Thomas, A.: Microporous Conjugated Poly(thienylene-arylene) Networks. *Adv. Mater.* **21**, 702-705, (2009).
- [11] Kuhn, P.; Antonietti, M.; Thomas, A.: Porous, Covalent Triazine-Based Frameworks Prepared by Ionothermal Synthesis. *Angew. Chem. Int. Ed.* **18**, 3450-3453, (2008).
- [12] Kuhn, P.; Forget, A.; Su, D. S.; Thomas, A.; Antonietti, M.: From Microporous Regular Frameworks to Mesoporous Materials with Ultrahigh surface Area: Dynamic Reorganization of Porous Polymer Networks. *J. Amer. Chem. Soc.* **40**, 13331-13337, (2008).
- [13] Kuhn, P.; Kruger, K.; Thomas, A.; Antonietti, M.: "Everything is surface": tunable polymer organic frameworks with ultrahigh dye sorption capacity. *Chem. Commun.* **44**, 5815-5817, (2008).
- [14] Kuhn, P.; Thomas, A.; Antonietti, M.: Toward Tailorable Porous Organic Polymer Networks: A High-Temperature Dynamic Polymerization Scheme Based on Aromatic Nitriles. *Macromolecules* **1**, 319-326, (2009).

Sustainable Functional Nanostructured Materials



The concept of Sustainable Chemistry represents an area of innovation, which not only preserves resources but also stands for a development process in the chemical industry. Sustainable Chemistry aspires to raise the stake of less dangerous chemicals as well as production of environmentally high-quality products from preferable renewable resources.

Our research is focused on the production of nanostructured materials of practical importance- starting from low cost natural precursors and using environmentally friendly processes. It is known that a material, regardless if organic or inorganic, improves its properties when scaled down to the nanometer region. Therefore mesoporous nanostructured materials such as polymers, carbons or metal oxides produced via a green chemistry route can offer attractive fields of applications e.g. in catalysis, chromatography, adsorption, sensors, energy storage and electrochemical processes.

Maria-Magdalena Titirici

24.03.1977

2000: Diploma in Chemistry

(University of Bucharest)

Thesis: Arylglyoxals-Synthesis, Characterization and Applications

2005: PhD, Natural Sciences

(University of Dortmund)

Thesis: Synthesis and Evaluation of Novel Formats in Molecular Imprinting

2005(s): Postdoc,

(Max-Planck Institute for Colloids and Interfaces, Potsdam)

2006(s): Group leader,

(Max-Planck Institute for Colloids and Interfaces Potsdam)

Hydrothermal Carbon

a) Nanostructured Carbon Materials

The synthesis of carbonaceous materials generally relies on very harsh conditions e.g. electric-arc discharge techniques, catalytical chemical vapour deposition, catalytic pyrolysis of organic compounds or high-temperature hydrothermal conversion at 800°C from amorphous carbon.

Therefore, the search for new strategies to generate carbon materials, carbon hybrids and related materials has been of major importance in material chemistry. Hydrothermal carbonization, involving the hydrothermal decomposition of various carbohydrates in aqueous solutions at 180°C represents one of these strategies towards a green and cheap method to directly produce spherically shaped functional carbon from carbohydrates (**Fig. 1**) [1, 2, 3]. A major advantage of this method is that due to the mild temperature conditions, the as synthesized particles contain functional groups confined to the surface and thus are hydrophilic. Therefore further activation processes are not necessary. Additionally, this enables us to further functionalize the particles in order to fit various applications.

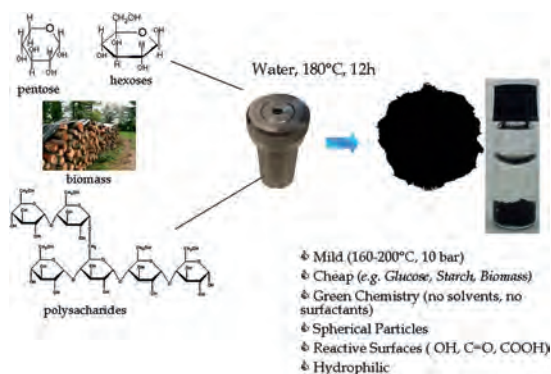

Fig. 1: Hydrothermal carbonization process

The porosity of hydrothermal carbon can be controlled by introducing suitable templates into the synthesis [4, 5]. Thus, performing the hydrothermal carbonization in the presence of various nanostructured silica materials followed by their removal we can produce mesoporous functional hydrophilic carbons materials. Such a low temperature route towards porous carbon materials with controllable surface functional groups and reactivity has a great potential for a variety of applications such as catalysis, chromatography, adsorption and Li insertion.

Another very interesting aspect of the hydrothermal carbonization process is that instead of pure carbohydrates, low value biomass residues can be used as a carbon precursor [6, 7]. This represents a meaningful way to transfer biomass into useful materials, more efficient energy carriers and/or carbon storage deposits therefore an efficient process to remove atmospheric CO₂ by fast growing plants, finally forming a carbon sequestering solid.

b) Carbon Nanocomposites

Using hydrothermal carbonization in the presence of water soluble metal salts or preformed nanoparticles, we can obtain carbon/metal (oxide) nanocomposites in a one step process [8]. These nanocomposites have important applications in the field of catalysis and electrochemistry. For example the hydrophilic C/Pd carbon nanocomposites were successfully used for the selective hydrogenation of phenol to cyclohexanone in aqueous phase [9]. Furthermore, the carbon matrix can be removed from these nanocomposites by simple calcination.

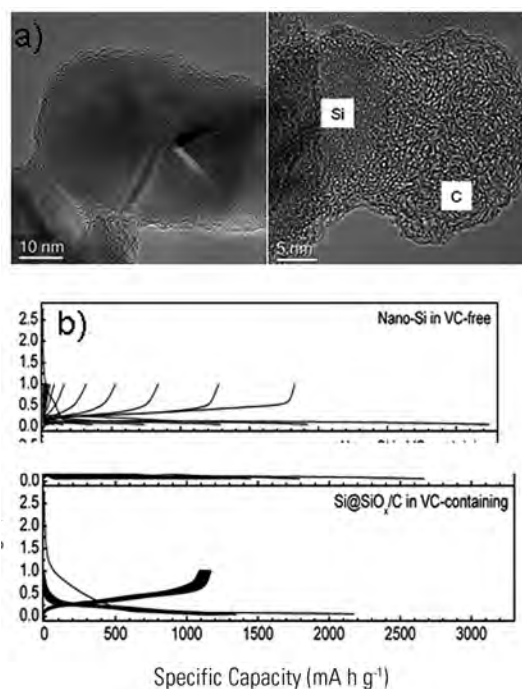

Fig.2: a) Silicon/carbon naocomposites showing core/shell morphology; b) Electrochemical performance of pure silicon nanoparticles (up image) in comparison with the carbon coated nanoparticles (down image) showing an improved cycling performance (60 cycles)

When coating silicon nanoparticles with hydrothermal carbon, a nanocomposite showing a significant improved lithium storage performance in terms of a highly reversible lithium storage capacity, excellent cycling performance and high rate capability has been obtained. This represents a promising candidate as an anode material in lithium-ion batteries (Fig. 2) [10, 11, 12].

Additionally, water soluble, functional organic monomers can also be introduced into this process resulting in carbonaceous materials with increased functionality with applications in water treatment or catalysis [13, 14]

c) Nitrogen-Doped Carbon

Recently, nitrogen-containing carbons are the subject of particular interest to researchers due to their remarkable performance in applications such as CO₂ sequestration, removals of contaminants from gas and liquid phases, environmental protection industry, catalysts and catalysts supports, or in electrochemistry as supercapacitors, cells and batteries to improve their capacity parameters.

Here, we present green and sustainable alternatives to produce nitrogen rich carbons which are based on the hydrothermal carbonization of nitrogen containing carbohydrates such as chitosane or glucosamine or on hydrothermal carbonization of glucose in the presence of different proteins (Fig. 3) [15, 16]. The resulting materials are carbon like material containing up to 9% nitrogen while the level of structural order can be improved by further carbonization at higher temperatures maintaining the nitrogen content constant. Given the simplicity of this method and the low cost of the starting precursors we believe that this method represents a sustainable alternative for the production of nitrogen containing materials.

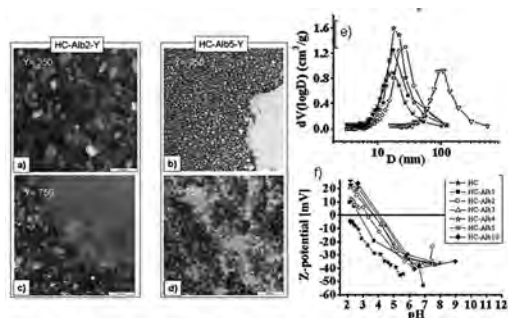

Fig.3: a) TEM micrograph of nitrogen doped carbon obtained from hydrothermal carbonization of glucose in the presence of a, b) 2% albumine; c, d) 5% albumine e) pore size distribution of the nitrogen doped materials showing their nanostructured character f) zeta potential measurements proving the positive charge of the materials at negatives pH due to nitrogen protonation

Smart Polymers

a) Thermoresponsive Polymers

Stimuli-responsive polymers can change their structural and physico-chemical properties in response to external signals. Among the thermo responsive polymers, poly-N-isopropylacrylamide (PNIPAAm) has the sharpest phase transition in the class of N-alkylacrylamide polymers. PNIPAAm exhibits

thermally reversible soluble-insoluble changes in aqueous solution as a response to temperature across a lower critical solution temperature (LCST) at 32°C. Due to this temperature dependent behaviour PNIPAAm grafted surfaces exhibit temperature-responsive hydrophilic-hydrophobic surface property alterations. Our research is focused in grafting of PNIPAAm and other thermoresponsive polymers, alone or in combination with other co-monomers, onto pre-synthesised silica or polymeric monoliths using controlled polymerization techniques [17]. The resulting monolithic hybrid material is used as a separation platform in chromatography for the separation of bioactive macromolecules in a pure aqueous environment and under isocratic conditions by simply changing the temperature of the chromatographic column [18]. Fig. 4 illustrates this concept for the separation of a mixture of steroids based on hydrophobic interactions.

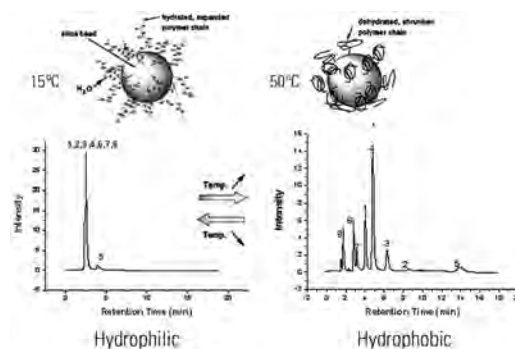

Fig.4: Temperature responsive chromatography of a mixture of steroids

b) Molecularly Imprinted Polymers

The assembly of a recognition site around a template molecule can be achieved within highly cross-linked polymeric matrices using molecularly imprinted techniques where the complementary functionality is introduced in the form of polymerisable monomers. We are interested in synthesizing molecular imprinted monoliths capable of recognizing and separating larger biomolecules such as peptides and proteins [19, 20]. Our procedure consists in immobilizing our target molecule or a small epitope of it onto the surface of a hierarchical porous silica monolith. After immobilization, the pore structure of the monolith is filled with a mixture of functional monomer and cross-linker. The functional monomer will interact with the pore-wall immobilized template, and following the removal of the silica monolith a polymeric monolithic materials will be obtain that will have the binding sites confined to the surface. This will allow substructures of larger molecules to be recognized by the surface-exposed sites. Furthermore, this process can be combined with the introduction of a thermoresponsive monomer resulting thus in stimuli responsive imprinted polymeric monolithic materials with great potential for separation science.

M. M. Titirici, R. Demir-Cakan, F. Roohi, S. Kubo, I Tan, J. Popovic, L. Zhao, D. Kopetzki, J. Roeser, R. White, F. Perez, R. Rothe, Former Group Members: N. Baccile
magdalena.titirici@mpikg.mpg.de

References:

- [1] Q. Wang, H. Li, L. Chen, X. Huang: Carbon **39**, 2211, (2001)
- [2] M.M. Titirici, M. Antonietti, N. Baccile: Green Chemistry **10**, 1204 (2008)
- [3] N. Baccile, G. Laurent, F. Babonneau, F. Fayon, M.M. Titirici, M. Antonietti: JACS-submitted (2009)
- [4] M.M Titirici, A Thomas, M. Antonietti: Adv. Funct. Mater **17**, 6, 1010 (2007)
- [5] M. M. Titirici, A. Thomas, M. Antonietti: J. Mater. Chem. **17**, 3412 (2007)
- [6] M. M. Titirici, A. Thomas, M. Antonietti: New J. Chem **31**, 787 (2007)
- [7] M. M. Titirici, A. Thomas, M. Antonietti: Chem. Mater. **19**, 4205 (2007)
- [8] M. M. Titirici, M. Antonietti, A. Thomas, Chem. Mater. **18**, 3808 (2006)
- [9] P. Makowski, R. Demir-Cakan, F. Goettmann, M. M. Titirici: Chem. Com. **999** (2008)
- [10] R. Demir-Cakan, Y. S Hu, M. Antonietti, J. Maier, M.M. Titirici: Chem. Mater. **20**(4), 1227 (2008)
- [11] Y.S.Hu, R. Demir-Cakan, M.M. Titirici, J. O. Müller, R. Schlögl, M. Antonietti, J. Maier: Angew. Chemie. Int. Ed **47**, (9), 1645 (2008)
- [12] R. Demir-Cakan M.M. Titirici, M. Antonietti, J. Maier, G. Cui, Y. S Hu: Chem. Com., 3759 (2008)
- [13] R. Demir-Cakan, N. Baccile, M. Antonietti, M. M. Titirici: Chem. Mater, 2009-accepted
- [14] R. Demir-Cakan, P. Makowski, M. Antonietti, F. Goettmann, M. M. Titirici, Chem. Com-submitted (2009)
- [15] N. Baccile, M. Antonietti, M.M Titirici: Adv. Funct. Mater-submitted (2009)
- [16] L Zhao, N. Baccile, S. Gross, M. Antonietti, M. M. Titirici: Green Chem. submitted
- [17] F. Roohi, M. M. Titirici: New J. Chem. **32**, 1409–1414 (2008)
- [18] F. Roohi, M. Antonietti, M. M. Titirici: J. Chromat A **160**, 1203 (2008)
- [19] M. M. Titirici, A. J. Hall, B. Sellergren Chem. Mater. **14**, 21 (2002)
- [20] M. M. Titirici, A. J. Hall, B. Sellergren: Chem. Mater **15**, 822 (2003)

DE NOVO NANOPARTICLES

De Novo Nanoparticles: Novel Synthetic Routes for Nanoparticle Production



1. Introduction

Nanoparticles are an astonishing type of matter. Simply by finely dispersing common bulk materials new properties can be observed [1]. This is mainly due to the fact that atoms at surfaces behave differently to those in the bulk, and nanoparticles are literally characterised by those surfaces. But there is more: when properly assembled or combined with well-known materials, the resulting nanostructures can show unexpected performances so that, for instance, inert materials can turn reactive, conductor when insulator, or simply harder, lighter, more robust, etc. The futuristic speech of Richard Feynman "There's plenty of room at the bottom" (1959) [2] from which the nanotechnology age had start, it is a concrete concept today and saying that nanotechnology will change human life, it is not too hazardous.

However, if unforeseeable behavior of materials at the nanoscale represent the charm of "nano-science", on the other hand it makes difficult to understand why such behaviour show up or can be tuned. For this reason, for many applications, appropriate nanostructures do not already exist or are not yet sustainable so that "de novo" systems have to be designed from scratch. This for instance holds for metal carbide and nitride particles, which offer new pathways for metal/base catalysis, but also as record holders in mechanical hardness or magnetization. This is also true for the corresponding borides, which are again new land for chemistry, when rational nanostructures are to be made.

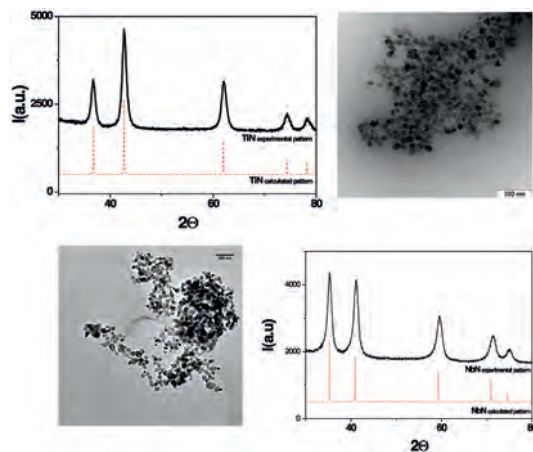

Fig. 1: Experimental (in black) and calculated (in red) WAXS diffraction patterns and corresponding TEM micrograph of TiN (up) and NbN (down) nanoparticles. Estimated sizes by Scherrer's equation: $d \sim 10$ nm in both cases

2. Metal Nitride and Metal Carbide

Metal carbides and nitrides nanoparticles are relevant materials for novel energy cycles and more efficient chemical reactions. In general, they possess strength and durability and can show optical, electronic and magnetic properties; as a consequence, they can be applied in many different fields.

Despite that, it is still necessary to establish a general, safe and competitive synthetic procedure to scale up their production for industry.

Recently we set up a simple, inexpensive and versatile route using urea to play a double role of nitrogen/carbon source and stabilizing agent. For the first time, metal carbides were obtained using urea as carbon-source [3]. Synthesized metal carbides and nitrides have sizes ranging between 5 and 20 nm in diameter and possess high specific surface area (between 50 and 200 m²/g), depending on the specific product (Tab.1). Furthermore, they are almost pure and highly crystalline (Fig.1-2). In particular, for metal nitride no larger contents of side products have been found, e.g. amorphous carbon, previously described in related processes as an inevitable companion of these nanostructures.

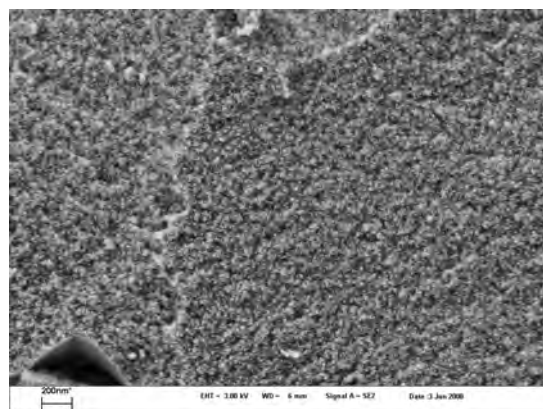

Fig. 2: SEM picture of WC (scale bar: 200 nm) illustrate the large scale homogeneity of the sample and the typical powder texture of very small particles. No structural side products can be seen.

Product	d (nm)	Surface area
TiN	10	~200
VN	15	~200
Fe ₃ C	30-40	~200
NbC	10	~80
W ₂ N WC	3-5 both cases	~20
Mo ₂ N Mo ₂ C	20-30 both cases	~50-80

3. Magnetic Nanostructures

In nanoscience, magnetic nanostructures have a special attraction, above all for their use as magnetic data storage, magnetic fluids, magnetic refrigerant and biomagnets.

In particular, iron carbide nanoparticles and nanostructures possess special interest for application such as superior magnetic recording, sensors, catalyst and in new nanoelectronic devices (e.g. in the production of functionalised carbon nanotubes)

With a similar procedure used to prepare MN and MC, highly crystalline Fe_3C have been prepared, simply by mixing an iron salt with 4, 5 dicyanoimidazole (to play the role of C-source). After heating treatment (750°C) under nitrogen flow, a silvery-black, non-corrosive and highly magnetic (when outer fields are applied) powder was obtained (named FeDI) and characterised by TEM and WAXS. TEM measurements (**Fig. 3A**) revealed the presence of fibres while WAXS (**Fig. 3B**) showed the crystallinity of the sample. Nevertheless, the broad peak around 26° (marked with a star) indicates the presence of amorphous carbon. Preliminary experiments showed that carbon contents can be however regulated, simply by playing with external parameter, such as the metal/C-source molar ratio, heating temperature and reaction time.

4. Boron-Based Nanomaterial

Due to their specific properties, boron based materials are attracting great interest [4], e.g. for the development of hard coatings, hydrogen storage devices, catalysts, insulators for electronic devices and sensors. As nanoparticles, they are expected to exhibit modified and/or enhanced properties. Synthesis of boron carbonitrides was made through a sacrificial hard template, ($\text{mpg-C}_3\text{N}_4$). Impregnation of the matrix with a borane complex BH_3 -amine and thermal post-treatment at 800°C leads to boron (carbo)nitrides of various B, C, N compositions, with $\text{B:N} = 1.1$ molar, irrespective of the initial borane. Use of volatile precursors such as BH_3 -*tert*-butylamine, BH_3 -dimethylamine and BH_3 -trimethylamine results in low carbon content ($\text{C:N} = 0.4$ molar) while the more stable and less volatile BH_3 -pyridine complex leads to a high carbon content ($\text{C:N} = 2.7$ molar). XRD patterns indicate that a turbostratic structure is obtained, whatever the boron precursor. This structure is lamellar and related to graphite and hexagonal boron nitride h-BN. SEM and TEM indicate that the resulting materials are composed of nanoparticles with a diameter of ca. 10 nm (**Fig. 4**), which corresponds to the size of the initial pores which act as nanoreactors for the decomposition of the borane complexes. Moreover, SEM shows the high homogeneity of the sample and no trace of mesoporous carbon was detected by TEM, thus confirming the formation of boron carbonitride nanoparticles.

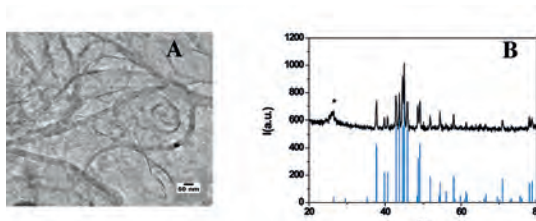

Fig. 3: A) TEM picture of FeDI sample and B) corresponding WAXS pattern (in black). In blue the calculated pattern for Fe_3C .

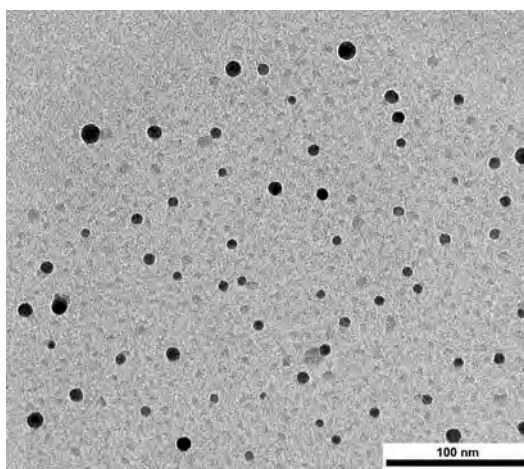

Fig. 4: TEM micrograph of boron carbonitride nanoparticles obtained after treatment for 6 h at 1000°C of a C_3N_4 mesoporous matrix impregnated with BH_3 -*tert*-butylamine.

C. Giordano, M. Antonietti, A. Kraupner, B. Milke, K. Ostwald, D. Portehault, W. Yao
cristina.giordano@mpikg.mpg.de

References:

- [1] A. P. Alivisatos: Semiconductor clusters, nanocrystals, and quantum dots. *Science* **271** (5251), 933-937 (1996).
- [2] R. Feynman: There's plenty of room at the bottom. (1959.)
Copyright of Engineering and Science
- [3] C. Giordano, C. Erpen, W. Yao, M. Antonietti: Synthesis of Mo and W Carbide and Nitride Nanoparticles via a Simple "Urea Glass" Route. *Nano Letters*, **8**, **12**, 4659-4663 (2008).
- [4] N. Patel, R. Fernandes, G. Guella, A. Kale, A. Miotello, B. Patton, C. Zanchetta: Structured and Nanoparticle Assembled Co-B Thin Films Prepared by Pulsed Laser Deposition: A Very Efficient Catalyst for Hydrogen Production. *J. Phys. Chem. C*, **112**, **17**, 6968-6976 (2008).

Artificial Photosynthesis



Natural photosynthesis feeds nearly all life on Earth either directly or indirectly by converting solar energy, carbon dioxide, and water into chemical energy and oxygen, and it has inspired artificial versions of photosynthesis, i.e. the splitting of water into its constituent elements and the conversion of carbon dioxide into organics via sunlight. An important challenge in artificial photosynthesis is to

develop efficient, stable, and inexpensive catalysts capable of harvesting visible light. There are countless trials to establish stable systems for this purpose, mostly based on inorganic semiconductors. We are investigating polymeric and organic-inorganic hybrid materials with controlled nanostructures as potential energy transducers for artificial photosynthesis

A. Photocatalytic Water Splitting

Water is an ideal source of hydrogen fuel. The inorganic catalysts developed for water splitting in the past 30 years have been metal-based. We have shown that an inexpensive, stable and metal-free polymeric material, graphitic carbon nitride ($g\text{-C}_3\text{N}_4$), (Fig. 1a), is able to catalyze hydrogen production from water with visible light [1, 2].

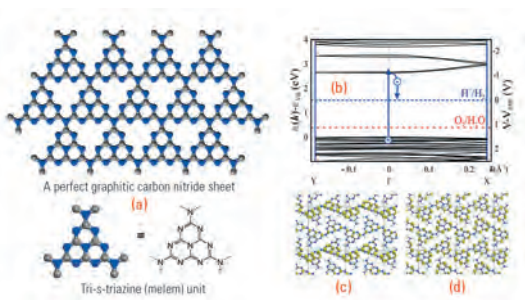

Fig. 1: (a) A perfect $g\text{-C}_3\text{N}_4$ sheet constructed from melem units. (b) Band structure for polymeric melon calculated along the chain. The position of the reduction level for H^+ to H_2 is indicated by the dashed blue line and the oxidation potential of H_2O to O_2 is indicated as the red dotted line just above the valence band. (c) The Kohn-Sham orbitals for the valence band of polymeric melon. (d) The corresponding conduction band. The carbon atoms are grey, nitrogen atoms are blue and the hydrogen atoms are white.

This polymer is stable in contact with water even at harsh acidic and basic environments, and can be made from easily available resources in flexible shapes and forms. The $g\text{-C}_3\text{N}_4$ sheet is calculated to feature an electronic band structure with band edges straddling H_2O redox potentials (Fig. 1b), and thus it is enabled to photo-split water

H_2 production was achieved by illuminating the mixture of $g\text{-C}_3\text{N}_4$ and water in the presence of triethanolamine to short cut the oxygen side of water hydrolysis. This system can produced 0.1-4 μmol of H_2 per hour without using any metals, depending on the batch. Notably, a differently modified $g\text{-C}_3\text{N}_4$ was also able to photocatalyze oxygen production from water with visible light.

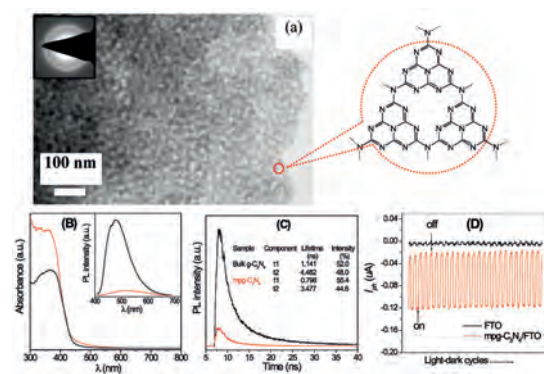

Fig. 2: (A) TEM image of $\text{mpg-C}_3\text{N}_4$, showing a 3D porous framework. The stacking distance of 0.332 nm is evident by the intense electron diffraction ring (inset). (B) Optical absorption spectrum and photoluminescence (PL) spectrum (inset) under 420 nm excitation and (C) time-resolved PL spectrum monitored at 525 nm under 420 nm excitation at 298 K for bulk $g\text{-C}_3\text{N}_4$ (black) and $\text{mpg-C}_3\text{N}_4$ (Red). (D) Periodic on/off photocurrent I_{ph} response of $\text{mpg-C}_3\text{N}_4$ electrode in 0.5 M Na_2SO_4 under zero bias in a standard two electrodes photoelectrochemical cell.

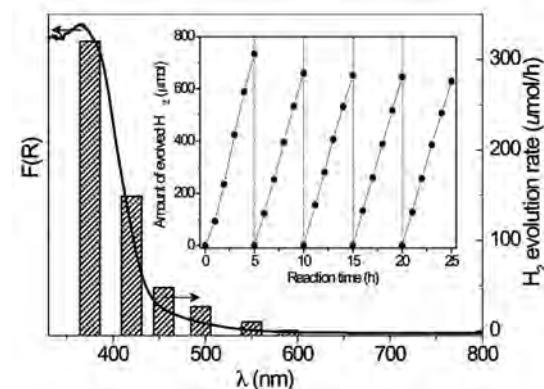

Fig. 3: Wavelength dependence of H_2 evolution rate on $\text{Pt/mpg-C}_3\text{N}_4$. The inset is the stability test for $\text{Pt/mpg-C}_3\text{N}_4$ under visible light irradiation (> 420 nm)

Xinchen Wang 25.09.1975

1999: B.Sc. Chemistry
(Fuzhou University, China)

Thesis: Preparation and photocatalytic activity of TiO_2 thin films

2005: PhD, Environmental Science
(The Chinese University of Hong Kong, China)

Thesis: Functionalized porous titania nanostructures as efficient photocatalysts

2005-2006: Postdoc

(Dept. Chem., The Chinese University of Hong Kong)

2006-2007: JSPS Research Fellow.

(Dept. Chem. Sys. Eng., The University of Tokyo)

2007-2009: Alexander von Humboldt Research Fellow

(Max Planck Institute of Colloids and Interfaces, Potsdam)

Since 2008: Group leader

(Max Planck Institute of Colloids and Interfaces, Potsdam)

Since 2008: Professor

(International Joint Laboratory, Fuzhou University, China)

We further advance $g\text{-C}_3\text{N}_4$ catalysts by protonation [3] and also by generating nanopore structures into the polymeric matrix [4] to improve their structural and electronic functions for solar energy conversion. The mesoporous $g\text{-C}_3\text{N}_4$ (mpg- C_3N_4) features unique semiconductor properties along with an open crystalline pore-wall and a large surface area (Fig. 2), which can in principle facilitate mass transfer and enhance light harvesting of the materials. Fig. 3 shows photocatalytic performance of mpg- C_3N_4 modified with Pt for hydrogen production from the photochemical reduction of water, which is by a factor of 8 higher than that of bulk Pt/ $g\text{-C}_3\text{N}_4$.

B. Combing Photocatalysis with Organosynthesis

The selective oxidation of organic molecules is of vital importance to chemical industry, especially using clean O_2 and H_2O_2 . Natural enzymes such as cytochrome P450, methane monooxygenases, and peroxidase are able to activate O_2 and H_2O_2 at mild conditions for biological oxidations, and thus they are blueprints for the design of environmentally-benign catalysts. A common feature of these natural enzymes is the complexation of iron with tetradentate N_4 -donor ligands in π -conjugated macrocyclic molecules. Iron-modified $g\text{-C}_3\text{N}_4$ ($\text{Fe-g-C}_3\text{N}_4$) features this catalytic structure, which, together with the ability of $g\text{-C}_3\text{N}_4$ to adsorb and activate benzene chemically motivate us to use it as an oxidation catalyst for the selective oxidation of benzene to phenol. [5]

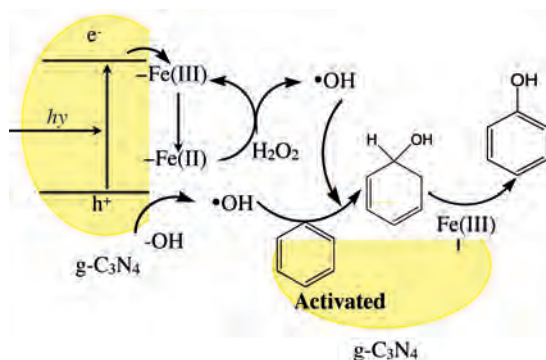

Scheme 1: The proposed coupling process of visible-light-induced redox catalysis with one-step phenol synthesis by $\text{Fe-g-C}_3\text{N}_4$

$\text{Fe-g-C}_3\text{N}_4$ is active for the direct oxidation of benzene to phenol using hydrogen peroxide, even at neutral pH without the aid of strong acids or alkaline promoters. By taking advantages of the photocatalytic functions of $g\text{-C}_3\text{N}_4$, the yield of the phenol synthesis can be markedly improved. The optimized benzene conversion reached 12% with 96% phenol selectivity (based on benzene) at mild conditions (60 °C, 4h). This solid-state bioinspired iron catalyst holds great promise for oxidation reactions in synthetic chemistry in general: it nicely combines photoredox catalysis with organosynthesis.

C. Environmental Purification

To design more efficient carbon nitride photocatalysts, it is desirable to extend the light absorption further into the visible spectrum. We show that appropriate amount of metal ions, e.g., Fe^{3+} , Zn^{2+} , and Cu^{2+} , can be included into the matrix of $g\text{-C}_3\text{N}_4$ by a simple soft chemical method. The metal components strongly modify the electronic properties of $g\text{-C}_3\text{N}_4$ extending the optical absorption to 650 nm (Fig. 4), and render the material with new functionalities such as mimicking metalloenzymes in the activation of H_2O_2 . The oxidative degradation of various organic dyes [e.g., rhodamine B (RhB), methylene blue, and methyl orange] can be achieved by using H_2O_2 and $\text{Fe-g-C}_3\text{N}_4$. Markedly, the overall efficiency of the process can be enhanced by photo-illumination. [6]

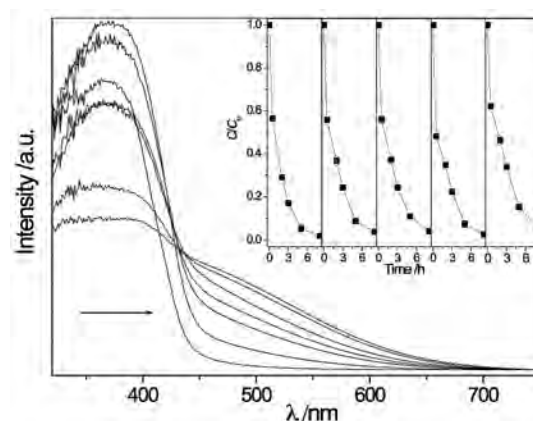

Fig. 4: Optical absorption spectra of $\text{Fe-g-C}_3\text{N}_4$ compared with that of $g\text{-C}_3\text{N}_4$. Arrow direction: $g\text{-C}_3\text{N}_4$, 1% $\text{Fe/g-C}_3\text{N}_4$, 3% $\text{Fe/g-C}_3\text{N}_4$, 5% $\text{Fe/g-C}_3\text{N}_4$, 10% $\text{Fe/g-C}_3\text{N}_4$, 15% $\text{Fe/g-C}_3\text{N}_4$, and 20% $\text{Fe/g-C}_3\text{N}_4$. The inset is cyclic run of RhB (10 μM) degradation by H_2O_2 (0.05 M) catalyzed by $\text{Fe-g-C}_3\text{N}_4$ catalyst (40 mg).

X. C. Wang, Y. J. Zhang, X. F. Chen, Y. Di, W. Yan, Y. Wang
xinchen.wang@mpikg.mpg.de

References:

- [1] Wang, X. C., Maeda, K., Thomas, A., Takanabe, K., Xin, G., Carlsson, J. M., Domen, K., Antonietti, M.: A metal-free polymeric photocatalyst for hydrogen production from water under visible light. *Nature Materials* **8**, 76-80 (2009).
- [2] Maeda, K., Wang, X. C., Nishihara, Y., Lu, D. L., Antonietti, M., Domen, K.: Photocatalytic activities of graphitic carbon nitride powder for water reduction and oxidation under visible light. *J. Phys. Chem. C*, revision submitted.
- [3] Zhang, Y. J., Thomas, A., Antonietti, M., Wang, X. C.: Activation of carbon nitride solid by protonation: morphology changes, enhanced ionic conductivity, and photoconduction experiments. *J. Am. Chem. Soc.* **131**, 50-51 (2009).
- [4] Wang, X. C., Maeda, K., Chen, X. F., Takanabe, K., Domen, K., Hou, Y. D., Fu, X. Z., Antonietti, M.: Polymer semiconductors for artificial photosynthesis: hydrogen evolution by mesoporous graphitic carbon nitride with visible light. *J. Am. Chem. Soc.*, in press.
- [5] Chen, X. F., Zhang, J. S., Wang, X. C., Fu, X. Z., Antonietti, M.: in preparation.
- [6] Wang, X. C., Chen, X. F., Thomas, A., Fu, X. Z., Antonietti, M.: Metal-containing carbon nitride compounds: a new functional organic/metal hybrid material. *Adv. Mater.*, in press.